

The Vehicle Weight and Dimension Regulations, 2010

being

[Chapter H-3.01 Reg 8](#) (effective November 12, 2010) as amended by Saskatchewan Regulations [46/2011](#), [13/2014](#), an [Errata Notice](#) published in Part II of the Gazette on May 2, 2014, an [Errata Notice](#) published in Part II of the Gazette on April 24, 2015, Saskatchewan Regulations [92/2015](#), [50/2018](#), [16/2019](#), [106/2020](#) and [81/2022](#).

NOTE:

This consolidation is not official. Amendments have been incorporated for convenience of reference and the original statutes and regulations should be consulted for all purposes of interpretation and application of the law. In order to preserve the integrity of the original statutes and regulations, errors that may have appeared are reproduced in this consolidation.

Table of Contents

PART I		PART IV	
Title and Interpretation		Vehicle Weights	
1	Title	15	Interpretation – Part IV
2	Interpretation	16	Tire and axle gross weights
PART II		17	Combination axle weights
Application and Requirements		18	Maximum gross vehicle weights
3	Application of regulations	19	Vehicles without rubber tires – maximum weight
4	Exempt items when determining dimensions	PART V	
5	General requirements	Overhanging Loads	
6	Requirements for axle groups	20	Overhanging loads
7	Requirements for lift axles	PART VI	
8	Prohibition re trucks and truck tractors equipped with a tridem drive axle group or tridem axle group	Permit Fees	
PART III		21	Repealed
Vehicle Dimensions		22	Fees for permits – over-weight vehicles
9	Maximum dimensions	23	Fees for permits – over-width and over-length vehicles
10	Minimum dimensions	23.1	Fees for permits – over-height vehicles
11	Conditions and restrictions re over-dimensional vehicles and loads	PART VII	
12	Prohibition on use of signs	Repeal and Coming Into Force	
13	Escort vehicles	24	R.R.S. c.H-3.01 Reg 2 repealed
14	Farm equipment dimensions	25	Coming into force
Appendices			
Appendix A		Vehicle Weight and Dimensions	
Appendix B		Requirements for Over-dimension D Signs	
Appendix C		Escort Vehicles	
Appendix D		Primary Highways	
Appendix E		Provincial Highways or Portions of Provincial Highways on Which B-trains Can Operate at 63,500 kg	

CHAPTER H-3.01 REG 8
The Highways and Transportation Act, 1997

PART I
Title and Interpretation

Title

1 These regulations may be cited as *The Vehicle Weight and Dimension Regulations, 2010*.

Interpretation

2(1) In these regulations:

- (a) **“A-dolly”** means a converter dolly that is towed from a single hitch located on the centre line of the towing unit;
- (b) **“A-train”** means a combination of vehicles composed of a truck tractor and a semi-trailer towing either:
 - (i) a semi-trailer with an A-dolly; or
 - (ii) a full trailer attached to the lead semi-trailer in the same manner as if an A-dolly were being used;
- (c) **“Act”** means *The Highways and Transportation Act, 1997*;
- (d) **“amber beacon”** means a flashing or rotating beacon, capable of emitting an amber light in all directions that is visible for a distance of 300 metres to other vehicles using the highway;
- (e) **“articulated bus”** means a bus that:
 - (i) has an articulation point between the passenger-carrying sections of the vehicle; and
 - (ii) is designed so that movement of passengers between the sections of the vehicle is possible at all times while the bus is being operated on a highway;
- (e.1) **“auto-carrier”** means a unit designed and used to transport automobiles, vans, small trucks and boats consisting of a truck tractor and semi-trailer;
- (f) **“auxiliary equipment”** means equipment that:
 - (i) is permanently mounted at the front, rear or sides of a vehicle; and
 - (ii) is not designed, intended or used to increase the load carrying capacity of the vehicle;
- (g) **“axle”** means an assembly of two or more wheels having a common axis of rotation through which weight is transmitted to a public highway;

H-3.01 REG 8 VEHICLE WEIGHT AND DIMENSION, 2010

- (h) **“axle group”** means any number of consecutive axles on a vehicle through which weight is to be equally distributed and transmitted to a highway so that the difference in weight on each axle in any axle group is not more than 1 000 kilograms from an adjacent axle;
- (i) **“axle spread”** means the distance between the extreme axle centres of an axle group;
- (j) **“axle unit”** means:
 - (i) a multiple axle group;
 - (ii) a single axle;
 - (iii) a single-half axle unit;
 - (iv) a tandem axle group;
 - (v) a tandem drive axle group;
 - (vi) a tridem axle group;
 - (vii) a tridem drive axle group; or
 - (viii) a wide-spread tandem axle group;
- (k) **“B-train”** means a combination of vehicles composed of a truck tractor and a semi-trailer towing another semi-trailer attached to a fifth wheel assembly mounted on the rear of the first semi-trailer;
- (l) **“box-length”** means:
 - (i) for a semi-trailer, subject to subclauses (ii) and (iii), the distance from the front of the semi-trailer to its rear, including the load but not including auxiliary equipment;
 - (ii) for an A-train, B-train or C-train, the distance from the front of the lead semi-trailer to the rear of the rearmost vehicle in the A-train, B-train or C-train, including the load but not including auxiliary equipment mounted on the lead semi-trailer; or
 - (iii) for a truck and trailer combination, the distance from the front of the load carrying area on the truck to the rear of the rearmost vehicle in the truck and trailer combination, including the load but not including auxiliary equipment;
- (m) **“bus”** means a motor vehicle designed and intended to carry more than 15 passengers;
- (n) **“C-dolly”** means a converter dolly that:
 - (i) has two parallel arms that connect to two hitches located on a towing unit so as to prevent any rotation in a horizontal plane through the hitch points;
 - (ii) has drawbars that are within 3° of level;
 - (iii) meets the C-dolly specifications set out in Standard 903 of the *Canadian Motor Vehicle Safety Standards*, being SOR/93-146; and

- (iv) is used with the dolly axle locked in the zero steer position at all times while travelling if:
- (A) one or more of the axle locking mechanisms are not in working condition; or
 - (B) the C-train is operated at a speed in excess of 50 kilometres per hour on any surface other than a dry, paved road;
- (o) **“C-train”** means a combination of vehicles composed of a truck tractor and a semi-trailer, followed by another full trailer attached to the first semi-trailer by means of a C-dolly;
- (p) **“combination of vehicles”** means two or more vehicles that are joined together;
- (q) **“combined weight”** means the sum of the gross weights for two adjacent axle units;
- (r) **“converter dolly”** means a device consisting of one or more axles, a fifth wheel assembly and one or more drawbars used to convert a semi-trailer to a full trailer;
- (s) **“D sign”** means a sign that meets the specifications set out in Appendix B;
- (t) **“drawbar”** means a structural member of a full trailer, pony trailer or trailer converter dolly that includes a device for the purpose of coupling with a trailer hitch or fifth wheel assembly;
- (u) **“drawbar length”** means the distance from the mid-point of the axle unit on a converter dolly to the hitch point on the vehicle towing the trailer;
- (v) **“effective overhang”** means the greater of the following:
- (i) the distance from the turn centre to the rearmost point of the truck, trailer or semi-trailer;
 - (ii) if there is a load on the truck, trailer or semi-trailer, the distance from the turn centre to the rearmost point of the load;
- (w) **“emergency vehicle”** means:
- (i) a vehicle that is used for the transportation of a peace officer in the performance of the peace officer’s duties;
 - (ii) a vehicle that is used for the transportation of a member of a fire department in response to or returning from an emergency or while being used to train a member of a fire department;
 - (iii) an ambulance; or
 - (iv) a vehicle or class of vehicles designated by the board as an emergency vehicle or class of emergency vehicles that is used in response to or returning from an emergency;
- (x) **“end dump semi-trailer”** means a semi-trailer designed so that its cargo carrying area may be raised to allow for the end dumping of its load;

- (y) **“escort vehicle”** means a single unit with two axles that meets the equipment requirements for escort vehicles set out in Appendix C;
- (z) **“farm equipment”** means equipment that is designed and intended for use in farming operations but does not include any of the following:
- (i) a truck;
 - (ii) a semi-trailer;
 - (iii) a full trailer;
 - (iv) a pony trailer;
 - (v) farm equipment that is loaded on a truck, trailer or semi-trailer; or
 - (vi) farm equipment that is towing equipment other than farm equipment;
- (aa) **“fifth wheel assembly”** means a coupling device that:
- (i) is securely attached to the chassis of a vehicle; and
 - (ii) consists of a skid plate, associated mounting brackets and a latching mechanism that couples or connects to a kingpin located on the other vehicles or component of the other vehicles, for the purpose of supporting or towing a semi-trailer;
- (bb) **“full trailer”** means a vehicle that is designed to be towed by another vehicle and is designed so that the whole of its weight is carried on its own axles and includes a semi-trailer and a converter dolly hitched together, but does not include:
- (i) recreational vehicles;
 - (ii) agricultural implements;
 - (iii) timbers or metal beams with wheels attached and used for the purpose of moving buildings;
 - (iv) asphalt distributors used for the construction or maintenance of bituminous surfaced highways; or
 - (v) pony trailers;
- (cc) **“gross vehicle weight”** means:
- (i) the combined weight of a vehicle and the load carried on that vehicle; or
 - (ii) the combined weight of two or more vehicles coupled or joined together and the combined weight of the loads carried on each of those vehicles;
- (dd) **“gross weight”** means the weight transmitted to the surface of a public highway through any areas of contact between the roadway surface and any vehicle;
- (ee) **“hitch offset”** means the distance from the towing vehicle turn centre to the centre of the hitching mechanism provided for towing a trailer;
- (ff) **“house trailer”** means a vehicle drawn by a motor vehicle and designed and intended for use as living quarters or office space;

(gg) “**interaxle spacing**” means the distance separating the centres of the nearest axles in two adjacent axle units;

(hh) “**kingpin setback**” means the longitudinal distance from the centre of the kingpin on a semi-trailer to any point on the semi-trailer, including its load, in front of the kingpin measured in the arc from the centre of the kingpin to the most distant point on the trailer or load in front of the kingpin excluding any auxiliary equipment, heater or refrigeration unit or aerodynamic device that is attached to the front of the semi-trailer and that is not designed for the transportation of goods;

(ii) “**lift axle**” means an axle of a vehicle that is constructed with a device capable of raising the wheels on that axle from contact with the highway;

(ii.1) “**ministry**” means the ministry over which the minister presides;

(jj) “**motor vehicle**” means a vehicle propelled or driven by any means other than by muscular power;

(kk) “**multiple axle group**” means an axle group of three or more equally spaced axles with an axle spread of not more than 4.5 metres, but does not include a tridem axle group;

(ll) “**pony trailer**” means a vehicle that is:

- (i) designed and intended to be towed by another vehicle;
- (ii) designed so that most of its weight is carried on its axles;
- (iii) equipped with a rigid drawbar; and
- (iv) equipped with only one axle unit;

but does not include a house trailer or recreational vehicle;

(mm) “**provincial road**” means any public highway shown as a provincial road on the current official highway map;

(nn) “**road construction and maintenance equipment**” means self-propelled or towed equipment used directly in road construction or maintenance, but does not include a truck, trailer, semi-trailer or any road construction or maintenance equipment transported on a truck, trailer or semi-trailer;

(nn.1) “**self-propelled equipment**” means machinery or equipment that:

- (i) moves under its own power;
- (ii) is not capable of exceeding a speed of 40 kilometres per hour; and
- (iii) uses a highway incidentally to its basic purpose;

(oo) “**semi-trailer**” means a vehicle with one axle unit that is designed for the transportation of goods and that is intended to be towed by another vehicle in a manner so that a substantial part of the weight of the vehicle being towed rests on or is being carried by the towing vehicle or trailer converter dolly through a fifth wheel assembly, but does not include:

- (i) a recreational vehicle;
- (ii) an agricultural implement;

(iii) timbers or metal beams with wheels attached that are used for the purpose of moving buildings;

(iv) an asphalt distributor used for the construction or maintenance of bituminous surfaced highways;

(v) a converter dolly; or

(vi) a pony trailer;

(pp) **“single axle”** means:

(i) any individual axle; or

(ii) any combination of two or more axles whose centres are less than one metre apart;

but does not include any axle within a tandem, wide-spread tandem, tridem or multiple axle group;

(qq) **“single-half axle unit”** means a group of two axles with four wheels on one axle and two single wheels on the second axle:

(i) whose centres are not less than one metre and not more than 1.85 metres apart; and

(ii) that is not subject to the axle group weight distribution requirements for adjacent axles;

(rr) **“steering axle”** means:

(i) the articulated axle or axles of a motor vehicle that are controlled by the vehicle operator and govern the direction travelled by the motor vehicle; or

(ii) an articulated axle on a trailer or semi-trailer where the direction of travel of the trailer is governed by the towing unit;

(rr.1) **“stinger-steer auto-carrier”** means a combination of vehicles designed and intended to carry automobiles or boats consisting of a truck tractor and semi-trailer where the fifth wheel is located on a drop frame behind and below the centre of the rearmost axle of the power unit;

(ss) **“tandem axle group”** means an axle group of two axles:

(i) whose centres are not less than one metre and not more than 1.85 metres apart; and

(ii) that is not part of a tridem or multiple axle group;

(tt) **“tandem drive axle group”** means a tandem axle group in which one or both axles in the group are connected to a power source that transmits tractive power to all wheels on that axle or those axles;

(uu) **“track width”** means the overall width of an axle measured from the outside of the outside tire located on one side of the vehicle to the outside of the outside tire located on that axle on the other side of the vehicle at any point above the lowest point of the rim;

(vv) **“trailer”** means a vehicle without motive power that is designed to be towed by another vehicle;

(ww) **“trailer wheelbase”** means, in the case of a vehicle with a gross vehicle weight exceeding 4 500 kilograms, the longitudinal distance from the turn centre of the vehicle to:

- (i) the centre of the kingpin of a semi-trailer;
- (ii) the centre of the turntable of a full trailer; or
- (iii) the centre of the hitching device of a pony trailer;

(xx) **“tridem axle group”** means an axle group of three equally spaced axles that:

- (i) has an axle spread of not less than 2.4 metres and not more than 3.7 metres; and
- (ii) is not part of a multiple axle group;

(yy) **“tridem drive axle group”** means a tridem axle group in which all axles in the group are connected to a power source that transmits tractive power to all wheels on those axles;

(zz) **“truck”** means a motor vehicle that:

- (i) is permanently fitted with a special purpose device; or
- (ii) is designed and normally used for the transportation of goods;

(aaa) **“truck tractor”** means a motor vehicle that is equipped with a fifth wheel assembly and that is designed to, and is primarily used to, pull a semi-trailer;

(bbb) **“truck wheelbase or truck tractor wheelbase”** means the longitudinal distance from the centre of the steering axle unit to the geometric centre of the drive axle unit;

(ccc) **“turn centre”** means the geometric centre of the axle group on a semi-trailer or pony trailer or the rear axle group on a truck, truck tractor or full trailer;

(ddd) **“urban municipality”** means:

- (i) a city as defined in *The Cities Act*;
- (ii) a town, village or resort village as defined in *The Municipalities Act*; or
- (iii) a town, northern village or northern hamlet as defined in *The Northern Municipalities Act*;

(eee) **“vehicle”** means a device, object or contrivance in, on or by which a person or thing is or may be transported on a highway and includes:

- (i) any load on or equipment attached to the vehicle; and
- (ii) any equipment that may be towed on a highway;

(fff) **“wide-spread tandem axle group”** means an axle group of two axles on a semi-trailer, full trailer and pony trailer where the axle group:

- (i) has centres that are greater than 1.85 metres apart and not more than 3.4 metres apart; and
- (ii) is not part of a tridem axle group;

H-3.01 REG 8 VEHICLE WEIGHT AND DIMENSION, 2010

(ggg) “**winter weight season**” means, subject to subsection (2), the period commencing on November 16 in one year and ending on March 14 of the following year.

(2) If the minister considers it necessary to protect the roadbed of all or any public highways, the minister may issue an order, in accordance with section 35 of the Act, restricting the winter weight season for the highway or highways mentioned in the order to the period specified in the order.

26 Nov 2010 cH-3.01 Reg 8 s2; 30 Jne 2011 SR 46/2011 s3; 11 Apr 2014 SR 13/2014 s3; 30 Oct 2015 SR 92/2015 s3; 15 Mar 2019 SR 16/2019 s3; 25 Sep 2020 SR 106/2020 s3; 28 Oct 2022 SR 81/2022 s3.

PART II

Application and Requirements

Application of regulations

3(1) Subject to subsections (2) to (7), these regulations apply to all vehicles that travel on or over public highways.

(2) These regulations do not apply to the following vehicles:

- (a) road construction and maintenance equipment moving on or over a public highway within the limits of the project on which they are being used;
- (b) motor graders, pavement-stripping equipment, or snow removal equipment operated by or on behalf of:
 - (i) the ministry; or
 - (ii) a municipality;
- (c) emergency vehicles.

(3) Section 9 does not apply to a vehicle with its load that is crossing a provincial highway or a provincial road by the most direct route at intersections that are not more than two kilometres apart.

(4) Section 7 does not apply to a three-axle truck that is equipped with a lift axle if the truck is registered in Class F pursuant to *The Vehicle Classification and Registration Regulations*.

(5) Subject to subsection (6), Part IV does not apply to any public highway or portion of a public highway that is within the boundaries of an urban municipality.

(6) Part IV does apply to any public highway or portion of a public highway that is within the boundaries of an urban municipality if the public highway or portion of the public highway:

- (a) is a provincial highway; or
- (b) is a direct extension of a provincial highway that directly connects:
 - (i) two or more provincial highways; or
 - (ii) to another direct extension of a provincial highway.

- (7) Part IV does not apply to farm equipment when it is operated or towed on or over a public highway.
- (8) Part IV does not apply to a vehicle with its load that is crossing a provincial highway or a provincial road by the most direct route that does not involve travel along the provincial highway or provincial road.

26 Nov 2010 cH-3.01 Reg 8 s3; 30 Jne 2011 SR
46/2011 s4; 17 Aug 2018 SR 49/2018 s3; 15 Mar
2019 SR 16/2019 s4; 28 Oct 2022 SR 81/2022 s4.

Exempt items when determining dimensions

- 4 In determining the dimensions of a vehicle for the purposes of section 9:
- (a) a rear view mirror is not included in determining the width of the vehicle, if the mirror does not extend more than 30 centimetres on each side of the vehicle;
 - (b) clearance lamps, dangerous goods placards, air or electrical connectors, anti-splash and anti-spray devices, auxiliary equipment and devices used to secure a load to a vehicle or the cover for a load on the vehicle are not included in determining the width of the vehicle, if they:
 - (i) do not increase the load carrying capacity of the vehicle; and
 - (ii) do not extend more than 10 centimetres on each side of the vehicle;
 - (c) auxiliary equipment that is mounted on the front or the rear of a truck tractor, truck, trailer or semi-trailer is not included in determining the length of the vehicle, if the equipment does not extend more than 10 centimetres beyond the front or rear of the vehicle;
 - (d) a heater or refrigeration unit attached to the front of the trailer or semi-trailer is not included in determining the length of the vehicle;
 - (e) a device designed and used to improve the aerodynamic performance of a vehicle that is mounted at the rear of a truck, trailer or semi-trailer is not included in determining the length of the vehicle, if:
 - (i) the device is flexible;
 - (ii) any portion of the device more than 1.9 metres above the ground does not protrude more than 1.52 metres beyond the rear of the vehicle;
 - (iii) any portion of the device within 1.9 metres of the ground does not protrude beyond a plane:
 - (A) starting from:
 - (I) the rear bottom edge of the rear impact guard; or
 - (II) the lowest point on the rear of the main part of the vehicle; and
 - (B) intersecting a point that is:
 - (I) 1.74 metres above the ground; and
 - (II) 1.21 metres behind the rear of the vehicle;

H-3.01 REG 8 VEHICLE WEIGHT AND DIMENSION, 2010

- (iv) the device is capable of being folded to within 0.305 metres of the rear of the vehicle; and
- (v) the device is not designed or used to increase the load carrying capacity of the vehicle;
- (f) except in the case of determining the overall length for a B-Train, a heavy duty bumper or device designed to reduce the impact of wildlife collisions that is mounted on the front of a truck or truck tractor is not included in determining the length of the vehicle, if the bumper or device does not extend more than 30 centimetres beyond the front of the vehicle.

26 Nov 2010 cH-3.01 Reg 8 s4; 30 Jne 2011 SR 46/2011 s5; 30 Oct 2015 SR 92/2015 s4; 17 Aug 2018 SR 50/2018 s3.

General requirements

- 5(1)** Subject to subsection (2), no person shall operate, or cause to be operated, a vehicle on a public highway unless the vehicle complies with these regulations.
- (2)** Subsection (1) does not apply to a person who has a permit issued pursuant to section 36 of the Act that authorizes the non-compliance.

26 Nov 2010 cH-3.01 Reg 8 s5.

Requirements for axle groups

- 6** Unless the person has a permit issued pursuant to section 36 of the Act authorizing the person to do so, no person shall operate, or cause to be operated, on or over a public highway:
 - (a) a vehicle or combination of vehicles using a group of axles that is not an axle unit;
 - (b) a vehicle equipped with more than two axle units; or
 - (c) a vehicle equipped with two axle units unless at least one axle unit is steerable.

30 Jne 2011 SR 46/2011 s6.

Requirements for lift axles

- 7(1)** Subject to subsections (2) to (4), no person shall operate, or cause to be operated, on or over a public highway a vehicle equipped with a lift axle if the tires of the lift axle are in contact with the ground.
- (2)** Subsection (1) does not apply if:
 - (a) the lift axle is on a vehicle other than a semi-trailer; and
 - (b) the person has a permit issued to section 36 of the Act authorizing the person to operate the vehicle if the tires of the lift axle are in contact with the ground.

- (3) Subsection (1) does not apply if:
- (a) the lift axle is on a semi-trailer;
 - (b) the lift axle was installed before November 1, 2010; and
 - (c) the control switch is located so that the vehicle operator is unable to raise the axles off the surface of the highway from inside the cab of the truck or truck tractor.
- (4) Subsection (1) does not apply if:
- (a) the lift axle is on a semi-trailer;
 - (b) the lift axle was installed on or after November 1, 2010;
 - (c) the lift axle system meets all of the following requirements:
 - (i) the lift axle system is designed so that the axles can be raised only when the semi-trailer is unladen;
 - (ii) the lift axle system is designed so that, on an unladen semi-trailer, the lift axle system can maintain an axle in the raised position once the axle is raised;
 - (iii) the lift axle system is designed so that, when the semi-trailer is carrying a load:
 - (A) all of the axles in the axle group are on the ground;
 - (B) none of the axles in the axle group can be raised by the lift axle; and
 - (C) the weight on the axle group is equally distributed;
 - (iv) the lift axle system is designed so that whether the axles are in the raised or lowered position, the trailer wheelbase and effective overhang conform to the limits set by these regulations; and
 - (d) the person has a permit issued pursuant to section 36 of the Act authorizing the person to use the lift axle system.

26 Nov 2010 cH-3.01 Reg 8 s7.

Prohibition re trucks and truck tractors equipped with a tridem drive axle group or tridem axle group

8(1) Unless the person has a permit issued pursuant to section 36 of the Act authorizing the person to do so, no person shall operate, or cause to be operated, on or over a public highway a combination of vehicles composed of a truck and a trailer or a truck tractor and a trailer, if the truck or truck tractor is equipped with a tridem drive axle group unless:

- (a) the trailer is attached to the truck or truck tractor through a fifth wheel assembly and the trailer is a semi-trailer; or

H-3.01 REG 8 VEHICLE WEIGHT AND DIMENSION, 2010

(b) the truck or truck tractor has a hitch offset not greater than 2.60 m, the trailer is a pony trailer, and the trailer meets the requirements as follows:

	Trailer wheelbase (m)	Maximum Axle Unit Weight (kg)
Trailer with a single axle	6.25 to 7.50	7 200
	Greater than 7.50	7 700
Trailer with a tandem axle group	6.25 to 7.50	11 000
	Greater than 7.50	12 000
Trailer with a tridem axle group	6.25 to 7.50	15 000
	Greater than 7.50	16 500

(2) Unless the person has a permit issued pursuant to section 36 of the Act authorizing the person to do so, no person shall operate, or cause to be operated, on or over a provincial highway or a provincial road a vehicle equipped with a tridem axle group if the axle-locking device on the tridem axle group is engaged.

(3) Unless the person has a permit issued pursuant to section 36 of the Act authorizing the person to do so, no person shall operate, or cause to be operated, on or over a provincial highway or provincial road a truck or truck tractor if the truck or truck tractor is equipped with a tridem axle group unless the tridem axle group is a tridem drive axle group.

26 Nov 2010 cH-3.01 Reg 8 s8; 11 Apr 2014 SR
13/2014 s4; Errata Notice 2 May 2014.

PART III Vehicle Dimensions

Maximum dimensions

9(1) Subject to subsection (2), unless the person has a permit issued pursuant to section 36 of the Act authorizing the person to do so, no person shall operate, or cause to be operated, on or over a provincial highway or a provincial road a vehicle or building that exceeds any of the following dimensions:

- (a) with respect to width:
 - (i) 2.6 metres; or
 - (ii) in the case of a house trailer and only if the house trailer is being moved between sunrise and sunset, 3.05 metres;
- (b) with respect to height, 4.15 metres;
- (c) with respect to length:
 - (i) 12.5 metres;

- (ii) subject to subclause (iii), in the case of any combination of vehicles, 23 metres;
- (iii) in the case of an articulated bus, 20 metres or 12.5 metres from the articulation point to the front or rear of the bus;
- (d) with respect to hitch offset:
 - (i) for a truck or truck tractor equipped with a single drive axle or a tandem drive axle group, a full trailer or a semi-trailer used as a towing unit, 1.8 m;
 - (ii) for a truck or truck tractor equipped with a tridem drive axle group used as a towing unit, 2.6 m.
- (2) In the case of a vehicle or combination of vehicles described in Appendix A, unless the person has a permit issued pursuant to section 36 of the Act authorizing the person to do so, no person shall operate, or cause to be operated, on or over a provincial highway or a provincial road a vehicle or combination of vehicles that exceeds any of the maximum dimensions set out in Appendix A for that vehicle or combination of vehicles.

26 Nov 2010 cH-3.01 Reg 8 s9; 11 Apr 2014 SR
13/2014 s5.

Minimum dimensions

- 10(1)** Unless the person has a permit issued pursuant to section 36 of the Act authorizing the person to do so, no person shall operate, or cause to be operated, on or over a provincial highway or a provincial road a vehicle or combination of vehicles that is of less than any of the minimum dimensions set out in Appendix A for that vehicle or combination of vehicles.
- (2) Subject to subsections (3) to (5), in the case of a full trailer or semi-trailer with a gross vehicle weight rating exceeding 10 000 kilograms, unless the person has a permit issued pursuant to section 36 of the Act authorizing the person to do so, no person shall operate, or cause to be operated, on or over a provincial highway or a provincial road a vehicle that has any of the following:
 - (a) a tridem axle group on a full trailer or semi-trailer manufactured on or after July 1, 1988 that has a track width of less than 2.5 metres;
 - (b) a tandem axle group on a full trailer or semi-trailer manufactured on or after January 1, 1992 that has a track width of less than 2.5 metres;
 - (c) a full trailer or semi-trailer, other than an end dump semi-trailer, that has a wheelbase of less than 6.25 metres.
- (3) Unless the person has a permit issued pursuant to section 36 of the Act authorizing the person to do so, no person shall operate, or cause to be operated, on or over a provincial highway or a provincial road a full trailer or semi-trailer with a track width of less than 2.5 metres unless:
 - (a) the full trailer or semi-trailer was manufactured before January 1, 2010;
 - (b) the axles on the full trailer or semi-trailer are fitted with single tires, each of which has a width of 445 millimetres or greater; and
 - (c) the axle or axle group on the full trailer or semi-trailer has a track width of greater than 2.3 metres.

H-3.01 REG 8 VEHICLE WEIGHT AND DIMENSION, 2010

(4) Unless the person has a permit issued pursuant to section 36 of the Act authorizing the person to do so, no person shall operate, or cause to be operated, on or over a provincial highway or a provincial road a full trailer or semi-trailer with a track width of less than 2.5 metres unless:

- (a) the full trailer or semi-trailer was manufactured on or after January 1, 2010;
- (b) the axles on the full trailer or semi-trailer are fitted with single tires, each of which has a width of 445 millimetres or greater; and
- (c) the axle or axle group on the full trailer or semi-trailer has a track width of greater than 2.45 metres.

(5) Unless the person has a permit issued pursuant to section 36 of the Act authorizing the person to do so, no person shall operate, or cause to be operated, on or over a provincial highway or a provincial road a full trailer or semi-trailer with a track width of less than 2.5 metres if the axles on the full trailer or semi-trailer were originally designed for dual tires but have been retrofitted with single tires unless:

- (a) the full trailer or semi-trailer was manufactured on or after January 1, 2010;
- (b) the axles on the full trailer or semi-trailer are fitted with single tires, each of which has a width of 445 millimetres or greater;
- (c) the axle or axle group on the full trailer or semi-trailer has a track width of greater than 2.45 metres; and
- (d) the full trailer or semi-trailer bears a label adjacent to the original compliance label that:
 - (i) identifies the company, authorized under the *Motor Vehicle Safety Act* (Canada), that retrofitted the axles; and
 - (ii) indicates the revised tire and wheel size designation and revised gross vehicle and axle weight ratings.

26 Nov 2010 cH-3.01 Reg 8 s10; 30 Jne 2011 SR
46/2011 s7.

Conditions and restrictions re over-dimensional vehicles and loads

11(1) No person shall operate, or cause to be operated, on or over a public highway:

- (a) subject to subsection (2), a vehicle or load exceeding 3.05 metres in width unless:
 - (i) it has a D sign, Wide Load sign or Oversize Load sign located at the front and rear of the vehicle; and
 - (ii) it is equipped for night travel, if it is being operated between sunset and sunrise, with a lamp that illuminates the sign at the rear of the vehicle or is equipped with an amber beacon mounted at the centre of the rear of the vehicle with the D sign, Wide Load sign or Oversize Load sign; or
- (b) subject to subsection (2), a vehicle or load exceeding 3.3 metres in width unless a minimum of one amber beacon is mounted on the cab of the towing unit.

- (c) a vehicle or load exceeding 3.05 m in width when visibility is reduced to less than 1 000 m.
- (2) Clauses (1)(a) and (b) do not apply to farm equipment being operated or towed if a permit pursuant to section 36 of the Act is not required to operate or tow that farm equipment.

26 Nov 2010 cH-3.01 Reg 8 s11; 30 Jne 2011 SR
46/2011 s8; 11 Apr 2014 SR 13/2014 s6.

Prohibition on use of signs

12 No person shall operate, or cause to be operated, on a provincial highway a vehicle displaying a D sign, Wide Load sign, Oversize Load sign or Long Load sign if those signs are not required by a permit or these regulations.

26 Nov 2010 cH-3.01 Reg 8 s12.

Escort vehicles

13(1) Subject to subsection (2), no person shall operate, or cause to be operated, an escort vehicle, unless:

- (a) that escort vehicle meets the requirements, and is operated in the manner, set out in Appendix C;
 - (b) a permit for exceeding the dimensions set out in section 9 is issued pursuant to section 36 of the Act; and
 - (c) the permit mentioned in clause (b) requires the permit holder to use an escort vehicle.
- (2) Clause (1)(a) does not apply if the permit states otherwise.

26 Nov 2010 cH-3.01 Reg 8 s13.

Farm equipment dimensions

14(1) Subject to subsection (2), farm equipment that exceeds a dimension set out in subsection 9(1) may be operated or towed without a permit between sunrise and sunset on or over a provincial highway.

(2) Subsection (1) does not apply if the farm equipment protrudes into another driving lane of a designated highway, unless:

- (a) the person operating or towing the farm equipment has a permit issued pursuant to section 36 of the Act authorizing the person to do so; or
 - (b) the protrusion is the result of passing or avoiding a vehicle or stationary object.
- (3) For the purposes of this section, “**designated highway**” means:
- (a) Provincial Highway No. 1;
 - (b) Provincial Highway No. 2, from Assiniboia to Chamberlain and from its north junction with Highway No. 11 to its junction with Highway No. 264;
 - (c) Provincial Highway No. 3, from Tisdale to its junction with Provincial Highway No. 40;

H-3.01 REG 8 VEHICLE WEIGHT AND DIMENSION, 2010

- (d) Provincial Highway No. 4, from its junction with No. 379 to its junction with No. 342 and from North Battleford to its junction with Highway No. 26;
- (e) Provincial Highway No. 5, from Watson to Saskatoon;
- (f) Provincial Highway No. 6, from Corinne to Melfort;
- (g) Provincial Highway No. 7;
- (h) Provincial Highway No. 9, from Junction No. 13 to Junction No. 48 and from Yorkton to Canora;
- (i) Provincial Highway No. 10;
- (j) Provincial Highway No. 11;
- (k) Provincial Highway No. 14, from Saskatoon to Biggar;
- (l) Provincial Highway No. 16;
- (m) Provincial Highway No. 18, from its junction with Provincial Highway No. 9 to its junction with Highway No. 39;
- (n) Provincial Highway No. 21, from Kindersley to Kerrobert;
- (o) Provincial Highway No. 22, from Esterhazy to its junction with Provincial Highway No. 9;
- (p) Provincial Highway No. 33, from 10 kilometres south-east of Regina to Regina;
- (q) Provincial Highway No. 35, from Tisdale to Nipawin;
- (r) Provincial Highway No. 39, from the International Boundary to Corinne;
- (s) Provincial Highway No. 41, from its junction with Highway No. 5 to its junction with Highway No. 27;
- (t) Provincial Highway No. 46;
- (u) Provincial Highway No. 55, from Prince Albert to its junction with Highway No. 120.

26 Nov 2010 cH-3.01 Reg 8 s14.

PART IV
Vehicle Weights

Interpretation – Part IV

15 In this Part and in Appendix A:

- (a) “**municipal highway**” means any public highway other than a provincial highway or a provincial road;
- (b) “**primary highway**” means the highways, or portions of the public highways, set out in Appendix D;
- (c) “**secondary highway**” means any provincial highway or provincial road that is not set out in Appendix D.

26 Nov 2010 cH-3.01 Reg 8 s15.

Tire and axle gross weights

16(1) Unless the person has a permit issued pursuant to section 36 of the Act authorizing the person to do so, no person shall operate, or cause to be operated, on or over a provincial highway, provincial road or municipal highway a vehicle or combination of vehicles that exceeds any of the gross weight limits specified for that vehicle or combination of vehicles in Appendix A or in this section.

(1.1) Unless the person has a permit issued pursuant to section 36 of the Act authorizing the person to do so, no person shall operate, or cause to be operated, on or over a provincial highway, provincial road or municipal highway a vehicle or combination of vehicles if the weight on the steering axle or axles is less than the weight prescribed in these regulations for that axle unit.

(2) Subject to subsections (3) to (4), the maximum gross weight on any tire is 10 kilograms per millimetre of tire width as determined by the manufacturer's width shown on the tire up to a maximum of 3 000 kilograms.

(3) The maximum gross weight on a tire on a steering axle is 10 kilograms per millimetre of tire width as determined by the manufacturer's width shown on the tire up to the steering axle weight limit maximum in Appendix A.

(3.1) The maximum steering axle weight for a truck tractor equipped with a single drive axle or a tandem drive axle group is 6 000 kilograms.

(3.2) The maximum steering axle weight for a truck tractor equipped with a tridem drive axle group is 7 300 kilograms.

(3.3) The maximum gross weight on any tire on self-propelled equipment operated on or over a provincial highway, provincial road or municipal highway is 10 kilograms per millimetre of tire width as determined by the manufacturer's width shown on the tire, up to a maximum of 5 500 kilograms.

(4) The maximum gross weight on a tire that has a width of 445 millimetres or greater is 10 kilograms per millimetre of tire width, up to a maximum of:

(a) 4550 kilograms on the highways or portions of primary highways listed in Appendix D;

(b) 3850 kilograms on provincial highways that are the subject of a minister's order made pursuant to clause 35.1(1)(d) of the Act that authorizes a person to operate a vehicle or class of vehicles on those highways specified in the order during the effective period of the order at the weights set for primary highways by these regulations; and

(c) 3850 kilograms on any other highways not mentioned in clauses (a) and (b) during the winter weights season.

(5) Subject to subsections (2) to (4), the maximum gross weight for a single axle or any axle within an axle group or axle unit is:

(a) subject to clause (d), 9 100 kilograms on a primary highway;

(b) subject to clause (d), 8 200 kilograms on a secondary highway;

(c) subject to clause (d), 8 200 kilograms on a municipal highway; and

(d) during winter weight season, 10 000 kilograms on highways mentioned in clauses (a) to (c).

H-3.01 REG 8 VEHICLE WEIGHT AND DIMENSION, 2010

(6) Subject to subsections (2) to (4), the maximum gross weight for a single-half axle unit is:

- (a) subject to clause (d), 12 750 kilograms on a primary highway;
- (b) subject to clause (d), 10 875 kilograms on a secondary highway;
- (c) subject to clause (d), 10 875 kilograms on a municipal highway; and
- (d) during winter weight season, 13 500 kilograms on highways mentioned in clauses (a) to (c).

(7) Subject to subsections (2) to (4) and (7.1), the maximum combined gross weight of a wide-spread tandem axle group is:

- (a) subject to clause (d), 9 100 kilograms on a primary highway;
- (b) subject to clause (d), 8 200 kilograms on a secondary highway;
- (c) subject to clause (d), 8 200 kilograms on a municipal highway; and
- (d) during winter weight season, 10 000 kilograms on highways mentioned in clauses (a) to (c).

(7.1) Subsection (7) does not apply to a semi-trailer equipped with a wide-spread tandem axle group.

(8) Subject to subsections (2) to (4), for a tandem axle group or any two adjacent axles within a tridem axle group, the maximum gross weight is:

- (a) subject to clause (d), 17 000 kilograms on a primary highway;
- (b) subject to clause (d), 14 500 kilograms on a secondary highway;
- (c) subject to clause (d), 14 500 kilograms on a municipal highway; and
- (d) during winter weight season, 18 000 kilograms on highways mentioned in clauses (a) to (c).

(9) Subject to subsections (2) to (4), for a tridem axle group other than a tridem drive axle group, the maximum gross weight is:

- (a) 24 000 kilograms on a primary highway, if the axle spread is greater than 3.6 metres but not greater than 3.7 metres;
- (b) subject to subsection (10), 23 000 kilograms on a primary highway, if the axle spread is greater than 3.0 metres but not greater than 3.6 metres;
- (c) 21 000 kilograms on a primary highway, if the axle spread is greater than 2.4 metres but not greater than 3.0 metres;
- (d) 20 000 kilograms on a secondary highway;
- (e) 20 000 kilograms on a municipal highway; and
- (f) during the winter weight season, weights as set out in clauses (a), (b) and (c) apply to the highways mentioned in clauses (d) and (e).

(10) Subject to subsections (2) to (4), if the axle spread of a tridem axle group is greater than 3.0 metres, but not greater than 3.6 metres, the maximum gross weight for that tridem axle group is 24 000 kilograms on:

- (a) the provincial highways or portions of provincial highways listed in Appendix E; and

(b) any public highway or portion of a public highway that is within the boundaries of an urban municipality if the public highway or portion of the public highway:

(i) is one of the provincial highways or portions of provincial highways listed in Appendix E; or

(ii) is a direct extension of one of the provincial highways or portions of provincial highways listed in Appendix E that directly connects:

(A) two or more provincial highways listed in Appendix E; or

(B) to another direct extension of a provincial highway listed in Appendix E.

(11) Subject to subsections (2) to (4), for a multiple axle group, the maximum gross weight is:

(a) 17 000 kilograms for a multiple axle group consisting of three or more axles with 12 or more tires; and

(b) 15 000 kilograms for a multiple axle group consisting of three or more axles with fewer than 12 tires.

26 Nov 2010 cH-3.01 Reg 8 s16; 11 Apr 2014 SR 13/2014 s7; 30 Oct 2015 SR 92/2015 s5; 17 Aug 2018 SR 50/2018 s4; 15 Mar 2019 16/2019 s5; 28 Oct 2022 SR 81/2022 s5.

Combination axle weights

17(1) Unless the person has a permit issued pursuant to section 36 of the Act authorizing the person to do so, no person shall operate, or cause to be operated, on or over a provincial highway, provincial road or municipal highway a vehicle or combination of vehicles that exceeds any of the combined weight limits specified for that vehicle or combination of vehicles in Appendix A or in this section.

(2) Subject to subsection (4), if the interaxle spacing between two axle units is less than the minimum interaxle spacing set out in subsection (3), the maximum combined weight for the axle units is the sum of the maximum gross weights for the two adjacent axle groups less 500 kilograms for every 0.1 metres, or portion thereof, that the interaxle spacing is less than the minimum interaxle spacing set out in subsection (3).

(3) The minimum interaxle spacing between two axle units is:

(a) for two single axles if the axles are not part of a wide-spread tandem axle group, tridem axle group or a multiple axle group, 3.0 metres;

(b) for a single axle and a tandem axle group, 3.0 metres;

(c) for a single axle and a tridem axle group, 3.0 metres;

(d) for two tandem axle groups, 5.0 metres;

(e) for a tandem axle group and a tridem axle group, 5.5 metres;

(f) for two tridem axle groups, 6.0 metres;

(g) for a multiple axle group and a single, tandem or tridem axle group, 5.5 metres.

H-3.01 REG 8 VEHICLE WEIGHT AND DIMENSION, 2010

- (4) In the case of an A-train or C-train, if the axle spacing between the rear axle unit on the lead trailer and the converter dolly axle unit is less than 3.0 metres:
- (a) the maximum combined weight for two single axles is 17 000 kilograms; and
 - (b) the maximum combined weight for a single axle and a tandem axle group is 23 000 kilograms.
- (5) In the case of an end dump semi-trailer manufactured before January 1, 1989, the maximum combined weight for a tandem axle group on the semi-trailer and an adjacent tandem axle group within a combination of vehicles is:
- (a) 32 000 kilograms, if the interaxle spacing is less than 5.0 metres but not less than 3.4 metres;
 - (b) 30 000 kilograms, if the interaxle spacing is less than 3.4 metres but not less than 3.0 metres; or
 - (c) 35 000 kilograms during the winter weight season for the axle group interaxle spacing listed in clause (a).
- (6) In the case of an end dump semi-trailer manufactured on or after January 1, 1989, the maximum combined weight for a tandem axle group on the semi-trailer and an adjacent tandem axle group within a combination of vehicles is:
- (a) 32 000 kilograms, if the interaxle spacing is less than 5.0 metres but not less than 4.5 metres;
 - (b) 30 000 kilograms, if the interaxle spacing is less than 4.5 metres but not less than 3.0 metres; or
 - (c) 35 000 kilograms during the winter weight season for the axle group interaxle spacing set out in clause (a).

26 Nov 2010 cH-3.01 Reg 8 s17; 11 Apr 2014 SR 13/2014 s8.

Maximum gross vehicle weights

- 18(1)** Unless the person has a permit issued pursuant to section 36 of the Act authorizing the person to do so, no person shall operate, or cause to be operated, on or over a provincial highway, provincial road or municipal highway a vehicle or combination of vehicles that exceeds any of the gross vehicle weight limits specified for that vehicle or combination of vehicles in Appendix A or in this section.
- (2) Subject to subsections (4) to (7) and to sections 16 and 17, the maximum gross vehicle weight for a vehicle or combination of vehicles listed in Appendix A is the sum of the axle unit weight limits up to the maximum gross vehicle weight limit for that vehicle or combination of vehicles.
- (3) Subject to subsections (4) to (7) and to sections 16 and 17, the maximum gross vehicle weight for a vehicle or combination of vehicles not listed in Appendix A or in this section is the sum of the axle unit weights to a maximum of:
- (a) 53 500 kilograms on a primary highway; and
 - (b) 49 000 kilograms on a secondary or municipal highway.
- (4) Subject to sections 16 and 17, the maximum gross vehicle weight for a B train is:
- (a) 63 500 kilograms on the provincial highways or portions of provincial highways listed in Appendix E; and

- (b) 63 500 kilograms on any public highway or portion of a public highway that is within the boundaries of an urban municipality if the public highway or portion of the public highway:
- (i) is one of the provincial highways or portions of provincial highways listed in Appendix E; or
 - (ii) is a direct extension of one of the provincial highways or portions of provincial highways listed in Appendix E that directly connects:
 - (A) two or more provincial highways listed in Appendix E; or
 - (B) to another direct extension of a provincial highway listed in Appendix E.
- (5) Unless the person has a permit issued pursuant to section 36 of the Act authorizing the person to do so, no person shall operate, or cause to be operated, a vehicle or combination of vehicles for which the gross vehicle weight exceeds:
- (a) **Repealed.** 30 Oct 2015 SR 92/2015 s6.
 - (b) **Repealed.** 30 Oct 2015 SR 92/2015 s6.
 - (c) 41 500 kilograms on:
 - (i) Provincial Road No. 905; or
 - (ii) Provincial Road No. 955 from the south abutment of the Douglas River Bridge to the northern-most limit of Provincial Road No. 955.
- (6) On those highways listed in subsection (7), unless the person has a permit issued pursuant to section 36 of the Act authorizing the person to do so, no person shall, during winter weight season, operate, or cause to be operated, a vehicle or combination of vehicles if:
- (a) the gross weights exceed those limits for secondary highways set out in Appendix A or in section 16; or
 - (b) the gross vehicle weights exceed those limits for secondary highways set out in Appendix A or in this section.
- (7) Subsection (6) applies to the following provincial highways and portions of provincial highways and provincial roads:
- (a) Provincial Highway No. 312 commencing at the western abutment of the Gabriel Dumont Bridge, eastward over the South Saskatchewan River;
 - (b) Provincial Road No. 919, from its junction with Provincial Highway No. 21 to the northern boundary of Meadow Lake Provincial Park;
 - (c) **Repealed.** 30 Oct 2015 SR 92/2015 s6.
 - (d) Old Nipawin Bridge located on the Provincial Road between its junction with Provincial Highway No. 35 in the Town of Nipawin and its junction with Provincial Highway No. 35/55 northwest of Nipawin.

H-3.01 REG 8 VEHICLE WEIGHT AND DIMENSION, 2010**Vehicles without rubber tires – maximum weight**

19 Notwithstanding sections 16 to 18, no person shall operate, or cause to be operated, on a public highway a vehicle, or combination of vehicles, without rubber tires that exceeds a gross vehicle weight of 10 000 kilograms.

26 Nov 2010 cH-3.01 Reg 8 s19.

PART V
Overhanging Loads

Overhanging loads

20(1) In this section, “**main part of the vehicle**” means the vehicle, but does not include any load on the vehicle or any auxiliary equipment or aerodynamic devices with the exception of a device designed and used to improve the aerodynamic performance of a vehicle that is mounted at the rear of a truck, trailer or semi-trailer meeting the requirements of subclauses 4(e)(i) to (v).

(2) Every registered owner and every driver of a vehicle operated on or over a public highway and transporting cargo shall comply with this Part.

(3) If a vehicle is transporting a load that overhangs the rear of the main part of the vehicle by one metre or more, the owner or operator shall ensure that there is displayed at the extreme rear end of the load:

(a) between sunrise and sunset, an orange or red flag of at least 300 millimetres by 300 millimetres; and

(b) between sunset and sunrise or when visibility is reduced, a lamp emitting a red light to the rear and to each side of the load that is visible for 200 metres.

(4) If a vehicle is transporting a load that overhangs either side of the main part of the vehicle by 300 millimetres or more, the registered owner or driver shall ensure that there is displayed at the extreme end or extreme ends of the overhanging load:

(a) between sunrise and sunset, an orange or red flag of at least 300 millimetres by 300 millimetres; and

(b) between sunset and sunrise or when visibility is reduced, a lamp emitting an amber light to the front and a red light to the rear of the vehicle that are visible for 200 metres.

26 Nov 2010 cH-3.01 Reg 8 s20; 30 Oct 2015 SR 92/2015 s7.

PART VI
Permit Fees

21 Repealed. 17 Aug 2018 SR 50/2018 s5.

Fees for permits – over-weight vehicles

22(1) In this section and in sections 23 and 23.1, “**permit**” means a permit issued pursuant to section 36 of the Act.

(2) The fee for a permit for an over-weight vehicle is \$15 plus any applicable fees set out in subsections (3) to (8).

- (3) If a permit is issued for a single trip providing for any axle unit to carry a weight exceeding the maximum allowable gross weight set out in these regulations, the fee is \$50 plus \$0.10 for each kilometre travelled.
- (4) Subject to subsection (6), if a permit for more than a single trip is issued to allow for any axle unit to carry a weight exceeding the maximum allowable gross weight set out in these regulations, the fee:
- (a) is \$100 per tonne, or part of a tonne, in excess of the allowable gross weight, per year; and
 - (b) is to be calculated on the basis of the gross weight carried by that axle unit that most exceeds the weight set out in these regulations.
- (5) If a permit described in subsection (4) is issued for a period of less than one year, the fee shall be prorated at the rate of one-twelfth for each month or part of a month for which the permit is issued, but the minimum fee payable is \$20.
- (6) If a permit is issued for a single trip providing for any group of axles that is not an axle unit, the fee is \$50 plus \$0.10 for each kilometre travelled.
- (7) If a permit is issued for a vehicle to transport a divisible load where the gross vehicle weight exceeds the maximum allowable gross vehicle weight limits and the permit is issued subject to an agreement entered into by the minister pursuant to clause 4(1)(g) or (h) of the Act, no fee is payable.
- (8) If a permit for a single trip of road construction and maintenance equipment is issued, the fee payable is \$20 plus \$0.20 for each kilometre travelled over 10 kilometres.

17 Aug 2018 SR 50/2018 s6; 15 Mar 2019
16/2019 s6.

Fees for permits – over-width and over-length vehicles

- 23(1)** In this section, “**EEMV agreement**” means an Energy Efficient Motor Vehicle Transportation Partnership Agreement entered into between the minister and a permit holder for the purpose of allowing the permit holder to operate an energy efficient motor vehicle.
- (2) Subject to subsection (3), the fee for a permit for an over-width or over-length vehicle is \$15 plus any applicable fees set out in subsections (4) to (6).
- (3) The fee for a permit for an over-length or over-width vehicle is \$15 if the permit is for:
- (a) moving a grain bin, hopper cone bottom, bin floor, or livestock shelter of any dimension;
 - (b) operating a vehicle of any dimension that is transporting a load of hay or straw;
 - (c) towing, operating or transporting farm equipment of any dimension, including the load or contents of any description; or
 - (d) towing, operating or transporting a vehicle or machinery of any dimension, including the load or contents of any description, on a provincial highway for a distance of not more than 10 kilometres.

H-3.01 REG 8 VEHICLE WEIGHT AND DIMENSION, 2010

- (4) If a permit is issued for an over-width vehicle or load:
- (a) the fee for a single trip permit is:
 - (i) in the case of a vehicle or load that is more than 2.6 metres wide but not more than 3.1 metres wide, nil;
 - (ii) in the case of a vehicle or load that is more than 3.1 metres wide but not more than 3.7 metres wide, \$17;
 - (iii) in the case of a vehicle or load that is more than 3.7 metres wide but not more than 4.3 metres wide, \$36; and
 - (iv) in the case of a vehicle or load that is more than 4.3 metres wide, \$72; and
 - (b) the fee for a multiple trip permit for one year for an over-width vehicle or load is:
 - (i) in the case of a vehicle or load that is more than 2.6 metres wide but not more than 3.1 metres wide, \$15;
 - (ii) in the case of a vehicle or load that is more than 3.1 metres wide but not more than 3.7 metres wide, \$100;
 - (iii) in the case of a vehicle or load that is more than 3.7 metres wide but not more than 4.3 metres wide, \$144; and
 - (iv) in the case of a vehicle or load that is more than 4.3 metres wide, \$144.
- (5) If a permit is issued for an over-width building, the fee for a permit is:
- (a) in the case of a building that is more than 2.6 metres wide but not more than 3.05 metres wide, nil;
 - (b) in the case of a building that is more than 3.05 metres wide but not more than 6.0 metres wide, \$36; and
 - (c) in the case of a building that is more than 6.0 metres wide, \$72.
- (6) If a permit is issued for an over-length vehicle:
- (a) the fee for a single trip permit is:
 - (i) in the case of a mobile home, nil; and
 - (ii) in the case of a vehicle that is more than 12.5 metres long, \$15;
 - (b) the fee for a multiple trip permit for one year for an over-length vehicle is:
 - (i) in the case of a vehicle that is more than 12.5 metres long but not more than 23 metres long, \$10;
 - (ii) in the case of a vehicle that is more than 23 metres long but not more than 29 metres long, \$60; and
 - (iii) in the case of a vehicle that is more than 29 metres long, \$120; and
 - (c) the fee for a multiple vehicle, multiple trip permit for one year issued to a permit holder operating under an EEMV agreement or a long combination vehicle permit is \$300.

Fees for permits – over-height vehicles

23.1(1) In this section, “**high-clearance corridor route**” means the following routes:

- (a) Provincial Highway No. 4, from the junction of Provincial Highway No. 15 to the junction of Provincial Highway No. 7;
 - (b) Provincial Highway No. 7, from Saskatoon to the Alberta Boundary;
 - (c) Provincial Highway No. 15, from Melville to Provincial Highway No. 4, including those portions of Provincial Highway No. 6 and Provincial Highway No. 20 required to connect north and south junctions of Provincial Highway No. 15;
 - (d) Provincial Highway No. 12 from Saskatoon to the junction of Provincial Highway No. 40;
 - (e) Provincial Highway No. 40 from the junction of Provincial Highway No. 12 to the junction of Provincial Highway No. 3;
 - (f) Provincial Highway No. 3 from the junction of Provincial Highway No. 40 east 9.9 km to the junction of municipal highway;
 - (g) municipal highway from the junction of Provincial Highway No. 3 and the municipal highway in clause (f) north 8.7 km, then east 35.8 km. to the junction of Provincial Highway No. 2;
 - (h) Provincial Highway No. 2 from the junction with the municipal highway in clause (g) north to the Christopher Lake access.
- (2) The fee for a permit for an over-height vehicle is \$15 plus any applicable fees set out in subsection (3).
- (3) If a permit is issued for an over-height vehicle in a high-clearance corridor route, the fee is:
- (a) in the case of a vehicle having a height that is more than 6 metres but less than 8.9 metres, \$1 plus \$0.20 for every 10 centimetres over 6 metres in height for each kilometre travelled; or
 - (b) in the case of a vehicle having a height of 8.9 metres or greater, \$6.80 for each kilometre travelled.

17 Aug 2018 SR 50/2018 s8; 28 Oct 2022 SR 81/2022 s7.

PART VII**Repeal and Coming Into Force****R.R.S. c.H-3.01 Reg 2 repealed**

24 *The Vehicle Weight and Dimension Regulations, 1999* are repealed.

26 Nov 2010 cH-3.01 Reg 8 s24.

Coming into force

25(1) Subject to subsection (2), these regulations come into force on November 1, 2010.

(2) If these regulations are filed with the Registrar of Regulations after November 1, 2010, these regulations come into force on the day on which they are filed with the Registrar of Regulations.

26 Nov 2010 cH-3.01 Reg 8 s25.

Appendix A

Vehicle Weight and Dimensions

[Subsection 9(2), subsection 10(1),
section 15, subsection 16(1), subsection 17(1) and section 18]

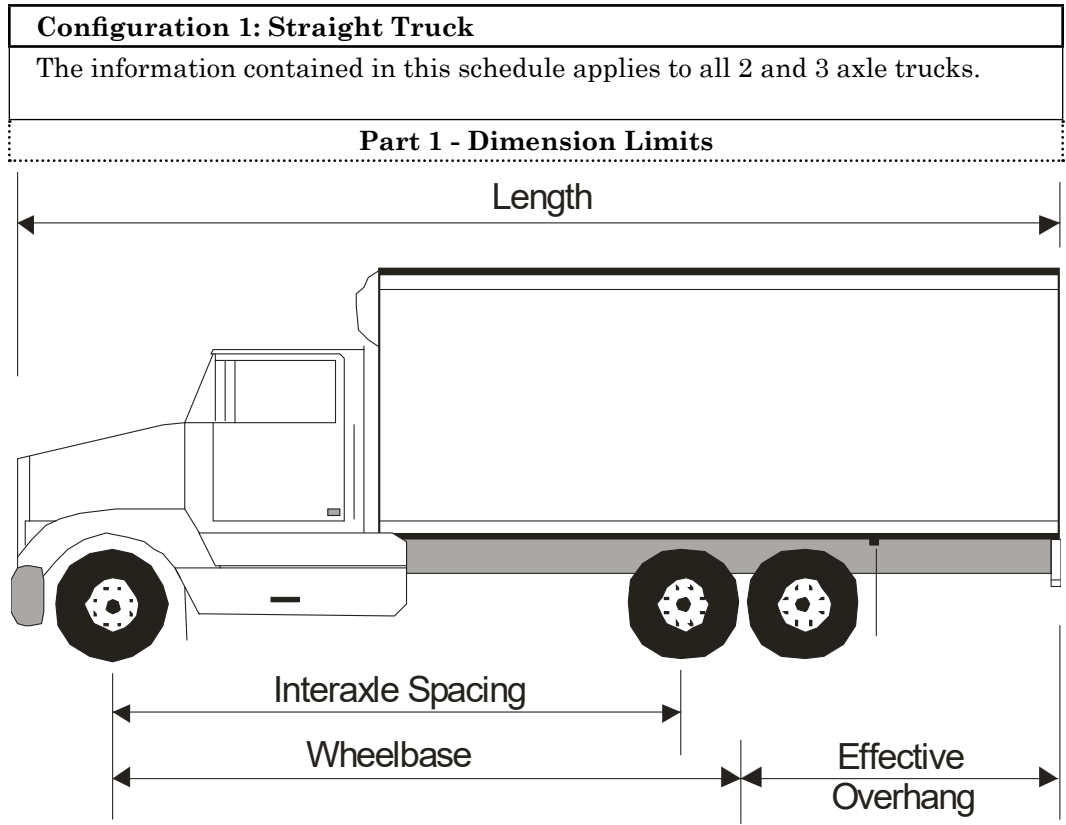

DIMENSION	LIMIT
Length	Maximum 12.5 m
Width	Maximum 2.6 m
Height	Maximum 4.15 m
Wheelbase	Not controlled
Tandem Axle Spread	Minimum 1.0 m/Maximum 1.85 m
Effective Overhang	Maximum 4.0 m
Interaxle Spacings	
Single Axle to Single Axle	Minimum 3.0 m
Single Axle to Tandem Drive Axle Group	Minimum 3.0 m

Configuration 1: Straight Truck

The information contained in this schedule applies to all 2 and 3 axle trucks.

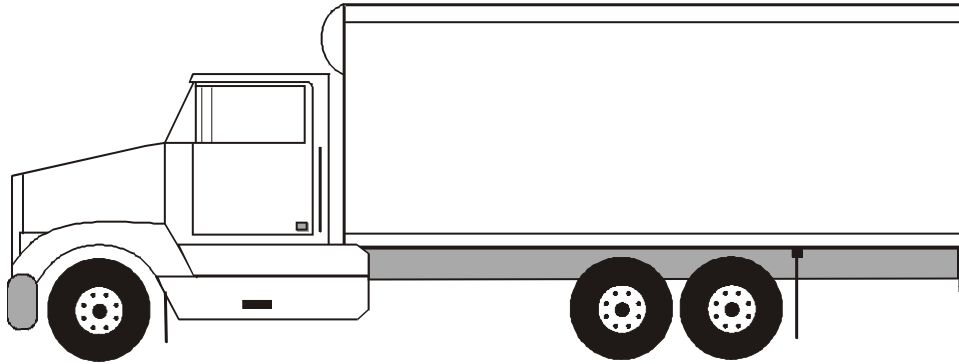
Part 2 - Weight Limits

WEIGHT LIMITS		
	Primary Highway	Secondary and Municipal Highways
1) <u>Steering Axle</u>	Maximum 7 300 kg	Maximum 5 500 kg
2) <u>Drive Axle Group</u>		
(a) Single Axle	Maximum 9 100 kg	Maximum 8 200 kg
(b) Tandem Axle Group	Maximum 17 000 kg	Maximum 14 500 kg
3) <u>Maximum Gross Vehicle Weights</u>		
(a) Two Axles	Maximum 16 400 kg	Maximum 13 700 kg
(b) Three Axles	Maximum 24 300 kg	Maximum 20 000 kg

WEIGHT LIMITS - Winter Weight Season		
	Primary Highway	Secondary and Municipal Highways
1) <u>Steering Axle</u>	Maximum 7 300 kg	Maximum 5 500 kg
2) <u>Drive Axle Group</u>		
(a) Single Axle	Maximum 10 000 kg	Maximum 10 000 kg
(b) Tandem Axle Group	Maximum 18 000 kg	Maximum 18 000 kg
3) <u>Maximum Gross Vehicle Weights</u>		
(a) Two Axles	Maximum 17 300 kg	Maximum 15 500 kg
(b) Three Axles	Maximum 25 300 kg	Maximum 23 500 kg

Configuration 2: Truck – Pony Trailer Combination
The information contained in this schedule applies to all 2 and 3 axle trucks in combination with a pony trailer.
Part 1 - Dimension Limits

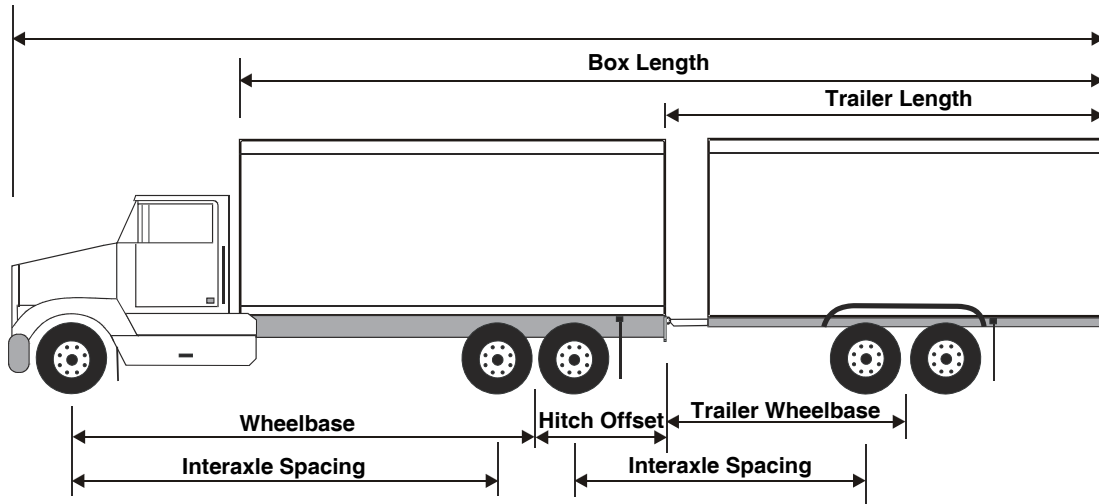

DIMENSION	LIMIT
Overall Length	Maximum 23.0 m
Width	Maximum 2.6 m
Height	Maximum 4.15 m
Box Length	Maximum 20.0 m
Truck:	
Wheelbase	Not controlled
Tandem Axle Spread	Minimum 1.0 m/Maximum 1.85 m
Effective Overhang	Maximum 4.0 m
Hitch Offset	Maximum 1.8 m

Configuration 2: Truck - Pony Trailer Combination (continued)	
DIMENSION	LIMIT
Pony Trailer	
Length (Note 1)	Maximum 12.5 m
Wheelbase (Note 1)	Minimum 6.25 m
Tandem Axle Group Spread (Note 1)	Minimum 1.0 m/Maximum 1.85 m
Tridem Axle Group Spread (Note 1)	Minimum 2.4 m/Maximum 2.5 m
Track Width (Note 1)	Minimum 2.5 m/Maximum 2.6 m
Effective Overhang (Note 1) (Note 2)	Maximum 4.0 m

Interaxle Spacings	
Single Axle to Single Axle	Minimum 3.0 m
Single Axle to Tandem Axle Group	Minimum 3.0 m
Single Axle to Tridem Axle Group	Minimum 5.0 m
Tandem Axle Group to Tandem Axle Group	Minimum 5.0 m
Tandem Axle Group to Tridem Axle Group	Minimum 5.5 m

Note 1: Does not apply to a pony trailer with a Gross Vehicle Weight Rating of less than 10 000 kg.

Note 2: The maximum effective overhang of 4.0 m applies to a pony trailer manufactured after June 30, 1988. For a pony trailer manufactured before July 1, 1988, the load is restricted to an effective overhang of 4.0 m or the rear of the trailer, whichever is greater.

Configuration 2: Truck – Pony Trailer Combination
The information contained in this schedule applies to all 2 and 3 axle trucks in combination with a pony trailer.
Part 2 - Weight Limits

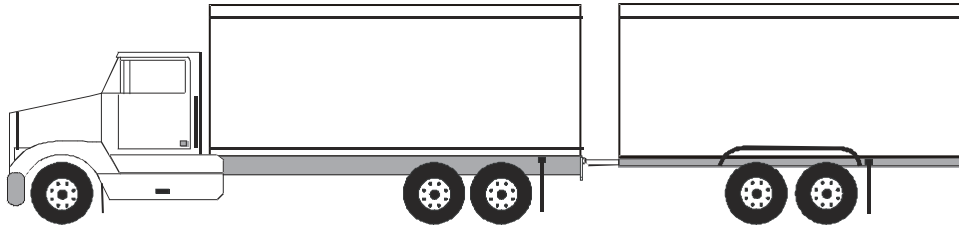

WEIGHT LIMITS		
	Primary Highway	Secondary and Municipal Highways
1) <u>Steering Axle</u>	Maximum 7 300 kg	Maximum 5 500 kg
2) <u>Drive Axle Group</u>		
(a) Single Axle	Maximum 9 100 kg	Maximum 8 200 kg
(b) Tandem Axle Group	Maximum 17 000 kg	Maximum 14 500 kg
3) <u>Pony Trailer Axle Group</u>		
(a) Single Axle	Maximum 9 100 kg	Maximum 8 200 kg
(b) Tandem Axle Group	Maximum 17 000 kg	Maximum 14 500 kg
(c) Tridem Axle Group	Maximum 21 000 kg	Maximum 20 000 kg

4) <u>Maximum Gross Vehicle Weights</u>		
(a) Two axle truck, single axle trailer	Maximum 25 500 kg	Maximum 21 900 kg
(b) Two axle truck, tandem axle trailer	Maximum 33 400 kg	Maximum 28 200 kg
(c) Two axle truck, tridem axle trailer	Maximum 37 400 kg	Maximum 33 700 kg
(d) Three axle truck, single axle trailer	Maximum 33 400 kg	Maximum 28 200 kg
(e) Three axle truck, tandem axle trailer	Maximum 41 300 kg	Maximum 34 500 kg
(f) Three axle truck, tridem axle trailer	Maximum 45 300 kg	Maximum 40 000 kg

Configuration 2: Truck – Pony Trailer Combination (continued)		
<i>WEIGHT LIMITS – Winter Weight Season</i>		
	Primary Highway	Secondary and Municipal Highways
1) <u>Steering Axle</u>	Maximum 7 300 kg	Maximum 5 500 kg
2) <u>Drive Axle Group</u>		
(a) Single Axle	Maximum 10 000 kg	Maximum 10 000 kg
(b) Tandem Axle Group	Maximum 18 000 kg	Maximum 18 000 kg
3) <u>Pony Trailer Axle Group</u>		
(a) Single Axle	Maximum 10 000 kg	Maximum 10 000 kg
(b) Tandem Axle Group	Maximum 18 000 kg	Maximum 18 000 kg
(c) Tridem Axle Group	Maximum 21 000 kg	Maximum 21 000 kg

4) <u>Maximum Gross Vehicle Weights</u>		
(a) Two axle truck, single axle trailer	Maximum 27 300 kg	Maximum 25 500 kg
(b) Two axle truck, tandem axle trailer	Maximum 35 300 kg	Maximum 33 500 kg
(c) Two axle truck, tridem axle trailer	Maximum 38 300 kg	Maximum 36 500 kg
(d) Three axle truck, single axle trailer	Maximum 35 300 kg	Maximum 33 500 kg
(e) Three axle truck, tandem axle trailer	Maximum 43 300 kg	Maximum 41 500 kg
(f) Three axle truck, tridem axle trailer	Maximum 46 300 kg	Maximum 44 500 kg

Configuration 3: Truck - Full Trailer Combination

The information contained in this schedule applies to all 2 and 3 axle trucks in combination with a full trailer or a semi-trailer and converter dolly.

Part 1 Dimension Limits

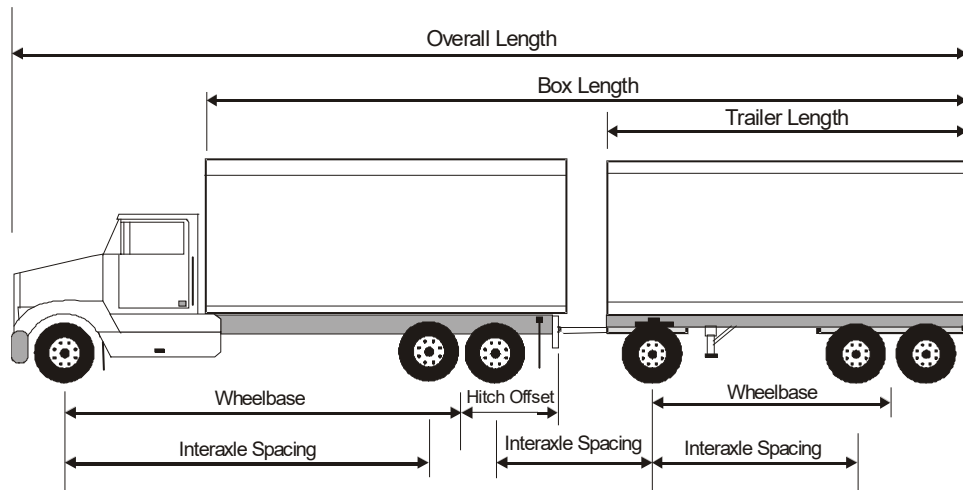

DIMENSION	LIMIT
Overall Length	Maximum 23 m
Overall Width	Maximum 2.6 m
Overall Height	Maximum 4.15 m
Box Length	Maximum 20 m

Truck:	
Length	Maximum 12.5 m
Wheelbase	Not controlled
Tandem Axle Spread	Minimum 1.0 m/Maximum 1.85 m
Effective Overhang	Maximum 4.0 m
Hitch Offset	Maximum 1.8 m

Configuration 3: Truck - Full Trailer Combination (continued)	
DIMENSION	LIMIT
Full Trailer	
Length	Maximum 12.5 m
Wheelbase	Minimum 6.25 m
Tandem Axle Spread	Minimum 1.0 m/Maximum 1.85 m
Track Width	Minimum 2.5 m/Maximum 2.6 m
Interaxle Spacings	
Single Axle to Single Axle or Tandem Axle Group	Minimum 3.0 m
Tandem Axle Group to Tandem Axle Group	Minimum 5.0 m

Configuration 3: Truck - Full Trailer Combination
The information contained in this schedule applies to all 2 and 3 axle trucks in combination with a full trailer or a semi-trailer and converter dolly.
Part 2 - Weight Limits

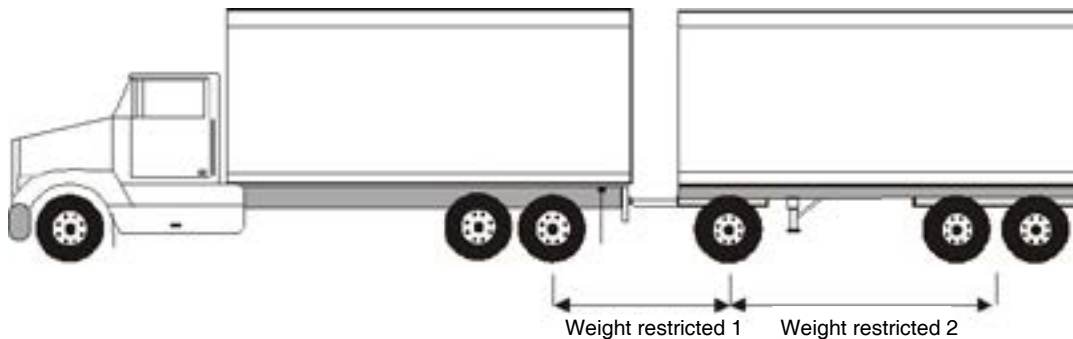

WEIGHT LIMITS		
	Primary Highway	Secondary and Municipal Highways
1) <u>Steering Axle</u>	Maximum 7 300 kg	Maximum 5 500 kg
2) <u>Drive Axle Group</u>		
(a) Single Axle	Maximum 9 100 kg	Maximum 8 200 kg
(b) Tandem Axle Group	Maximum 17 000 kg	Maximum 14 500 kg

3) <u>Full Trailer Axle Groups</u> (a) Single Axle (b) Tandem Axle Group	Maximum 9 100 kg Maximum 17 000 kg	Maximum 8 200 kg Maximum 14 500 kg
4) <u>Full Trailer Gross Weights</u> (Note 1) (a) Two axle truck, with a Two, three or four axle trailer (b) Three axle truck, with a Two axle trailer Three axle trailer Four axle trailer	Maximum 17 000 kg Maximum 17 000 kg Maximum 24 000 kg Maximum 31 000 kg	Maximum 14 500 kg Maximum 16 400 kg Maximum 22 700 kg Maximum 29 000 kg
5) <u>Maximum Gross Vehicle Weights</u> (a) Two axle truck, with a Two, three or four axle trailer (b) Three axle truck, with a Two axle trailer Three axle trailer Four axle trailer	Maximum 33 400 kg Maximum 41 300 kg Maximum 48 300 kg Maximum 55 300 kg	Maximum 28 200 kg Maximum 36 400 kg Maximum 42 700 kg Maximum 49 000 kg

Weight Restricted 1: Refer to section 17

Note 1 (Weight Restricted 2): The maximum allowable weight of a full trailer is restricted.

Configuration 3: Truck - Full Trailer Combination (continued)		
WEIGHT LIMITS - Winter Weight Season		
	Primary Highway	Secondary and Municipal Highways
1) <u>Steering Axle</u>	Maximum 7 300 kg	Maximum 5 500 kg
2) <u>Drive Axle Group</u> (a) Single Axle (b) Tandem Axle Group	Maximum 10 000 kg Maximum 18 000 kg	Maximum 10 000 kg Maximum 18 000 kg
3) <u>Full Trailer Axle Groups</u> (a) Single Axle (b) Tandem Axle Group	Maximum 10 000 kg Maximum 18 000 kg	Maximum 10 000 kg Maximum 18 000 kg
4) <u>Full trailer Gross Weights (Note 1)</u> (a) Two axle truck, with a Two, three or four axle trailer (b) Three axle truck, with a Two axle trailer Three axle trailer Four axle trailer	Maximum 17 000 kg Maximum 17 000 kg Maximum 24 000 kg Maximum 31 000 kg	Maximum 17 000 kg Maximum 17 000 kg Maximum 24 000 kg Maximum 31 000 kg
5) <u>Maximum Gross Vehicle Weights</u> (a) Two axle truck, with a Two, three or four axle trailer (b) Three axle truck, with a Two axle trailer Three axle trailer Four axle trailer	Maximum 34 300 kg Maximum 42 300 kg Maximum 49 300 kg Maximum 56 300 kg	Maximum 32 500 kg Maximum 40 500 kg Maximum 47 500 kg Maximum 54 500 kg

Note 1 (Weight Restricted 2): The maximum allowable weight of a full trailer is restricted

Configuration 4: Twin Steer Tandem Drive Truck

The information contained in this schedule applies to all twin steer tandem drive trucks.

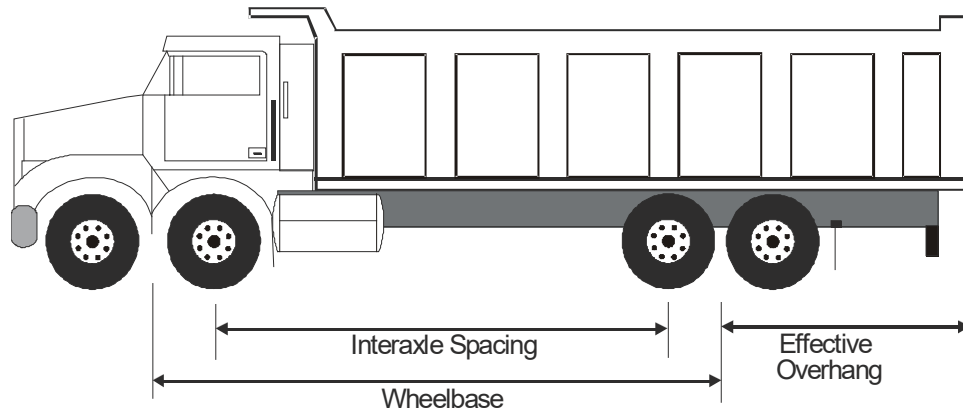
Part 1 - Dimension Limits

DIMENSION	LIMIT
Overall Length	Maximum 12.5 m
Overall Width	Maximum 2.6 m
Overall Height	Maximum 4.15 m
Truck:	
Wheelbase	Not Controlled
Tandem Steering Axle Group Spread	Minimum 1.0 m/Maximum 1.85 m
Tandem Drive Axle Group Spread	Minimum 1.0 m/Maximum 1.85 m
Effective Overhang	Maximum 4.0 m
Interaxle Spacing	
Tandem Axle Group to Tandem Axle Group	Minimum 5.0 m

Configuration 4: Twin Steer Tandem Drive Truck

The information contained in this schedule applies to all twin steer tandem drive trucks.

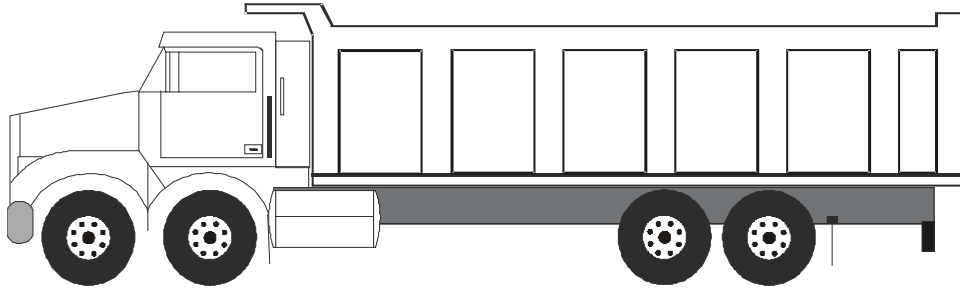
Part 2 – Weight Limits

WEIGHT LIMITS		
	Primary Highway	Secondary and Municipal Highways
1) <u>Tandem Steering Axle Group</u>	Maximum 13 600 kg	Maximum 11 000 kg
2) <u>Tandem Drive Axle Group</u>	Maximum 17 000 kg	Maximum 14 500 kg
3) <u>Maximum Gross Vehicle Weight</u>	Maximum 30 600 kg	Maximum 25 500 kg

WEIGHT LIMITS – Winter Weight Season		
	Primary Highway	Secondary and Municipal Highways
1) <u>Tandem Steering Axle Group</u>	Maximum 13 600 kg	Maximum 11 000 kg
2) <u>Tandem Drive Axle Group</u>	Maximum 18 000 kg	Maximum 18 000 kg
3) <u>Maximum Gross Vehicle Weight</u>	Maximum 31 600 kg	Maximum 29 000 kg

Configuration 5: Twin Steer Tandem Drive Truck – Pony Trailer Combination

The information contained in this schedule applies to all twin steer tandem drive trucks in combination with a pony trailer.

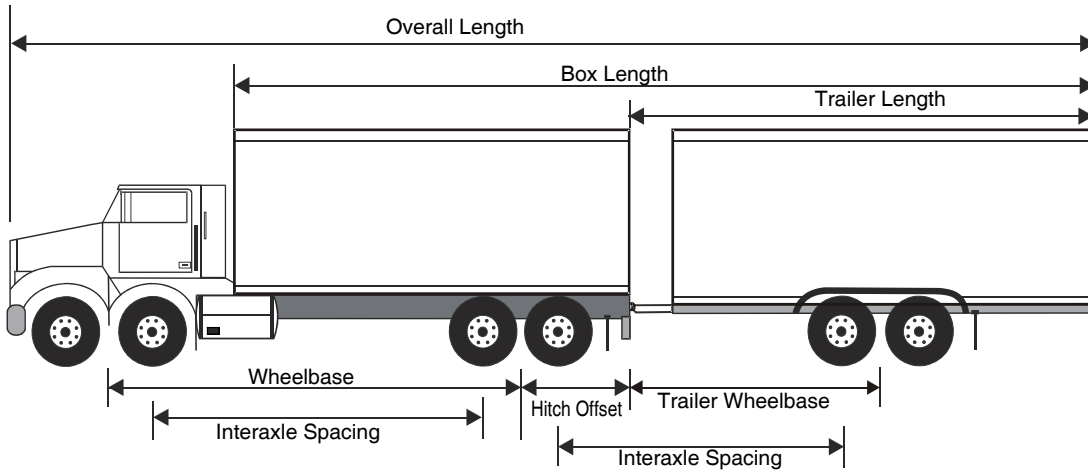
Part 1 – Dimension Limits

DIMENSION	LIMIT
Overall Length	Maximum 23.0 m
Width	Maximum 2.6 m
Height	Maximum 4.15 m
Box Length	Maximum 20.0 m
Truck:	
Wheelbase	Not Controlled
Tandem Steering Axle Group Spread	Minimum 1.0 m/Maximum 1.85 m
Tandem Drive Axle Group Spread	Minimum 1.0 m/Maximum 1.85 m
Effective Overhang	Maximum 4.0 m
Hitch Offset	Maximum 1.8 m

Configuration 5: Twin Steer Tandem Drive Truck - Pony Trailer Combination (continued)	
DIMENSION	LIMIT
Pony Trailer	
Length	Maximum 12.5 m
Wheelbase (Note 1)	Minimum 6.25 m
Tandem Axle Group Spread (Note 1)	Minimum 1.0 m/Maximum 1.85 m
Tridem Axle Group Spread (Note 1)	Minimum 2.4 m/Maximum 2.5 m
Track Width (Note 1)	Minimum 2.5 m/Maximum 2.6 m
Effective Overhang (Note 1) (Note 2)	Maximum 4.0 m
Interaxle Spacings	
Tandem Axle Group to Single Axle	Minimum 3.0 m
Tandem Axle Group to Tandem Axle Group	Minimum 5.0 m
Tandem Axle Group to Tridem Axle Group	Minimum 5.5 m

Note 1: Does not apply to a pony trailer with a Gross Vehicle Weight Rating of less than 10 000 kg.

Note 2: The maximum effective overhang of 4.0 m applies to a pony trailer manufactured after June 30, 1988. For a pony trailer manufactured before July 1, 1988, the load is restricted to an effective overhang of 4.0 m or the rear of the trailer, whichever is greater.

Configuration 5: Twin Steer Tandem Drive Truck - Pony Trailer Combination
The information contained in this schedule applies to all twin steer tandem drive trucks in combination with a pony trailer.
Part 2 - Weight Limits

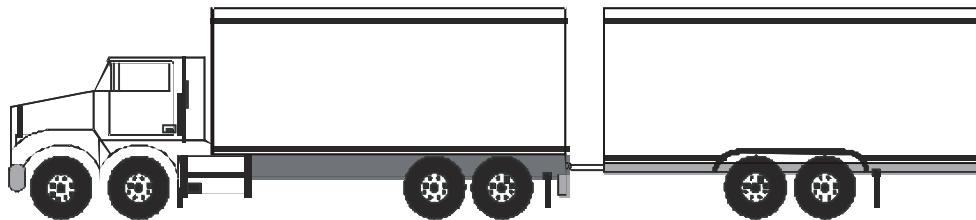

WEIGHT LIMITS		
	Primary Highway	Secondary and Municipal Highways
1) <u>Tandem Steering Axle</u>	Maximum 13 600 kg	Maximum 11 000 kg
2) <u>Tandem Drive Axle Group</u>	Maximum 17 000 kg	Maximum 14 500 kg

3) <u>Pony Trailer Axle Group</u>		
(a) Single Axle	Maximum 9 100 kg	Maximum 8 200 kg
(b) Tandem Axle Group	Maximum 17 000 kg	Maximum 14 500 kg
(c) Tridem Axle Group	Maximum 21 000 kg	Maximum 20 000 kg
4) <u>Maximum Gross Vehicle Weights</u>		
(a) Truck with single axle trailer	Maximum 39 700 kg	Maximum 33 700 kg
(b) Truck with tandem axle trailer	Maximum 47 600 kg	Maximum 40 000 kg
(c) Truck with tridem axle trailer	Maximum 51 600 kg	Maximum 45 500 kg

Configuration 5: Twin Steer Tandem Drive Truck - Pony Trailer Combination (continued)		
<i>WEIGHT LIMITS - Winter Weight Season</i>		
	Primary Highway	Secondary and Municipal Highways
1) <u>Tandem Steering Axle</u>	Maximum 13 600 kg	Maximum 11 000 kg
2) <u>Tandem Drive Axle Group</u>	Maximum 18 000 kg	Maximum 18 000 kg
3) <u>Pony Trailer Axle Group</u>		
(a) Single Axle	Maximum 10 000 kg	Maximum 10 000 kg
(b) Tandem Axle Group	Maximum 18 000 kg	Maximum 18 000 kg
(c) Tridem Axle Group	Maximum 21 000 kg	Maximum 21 000 kg
4) <u>Maximum Gross Vehicle Weights</u>		
(a) Truck with single axle trailer	Maximum 41 600 kg	Maximum 39 000 kg
(b) Truck with tandem axle trailer	Maximum 49 600 kg	Maximum 47 000 kg
(c) Truck with tridem axle trailer	Maximum 52 600 kg	Maximum 50 000 kg

Configuration 6: Twin Steer Tandem Drive Truck - Full Trailer Combination

The information contained in this schedule applies to all twin steer tandem drive trucks in combination with a full trailer or a semi-trailer and converter dolly.

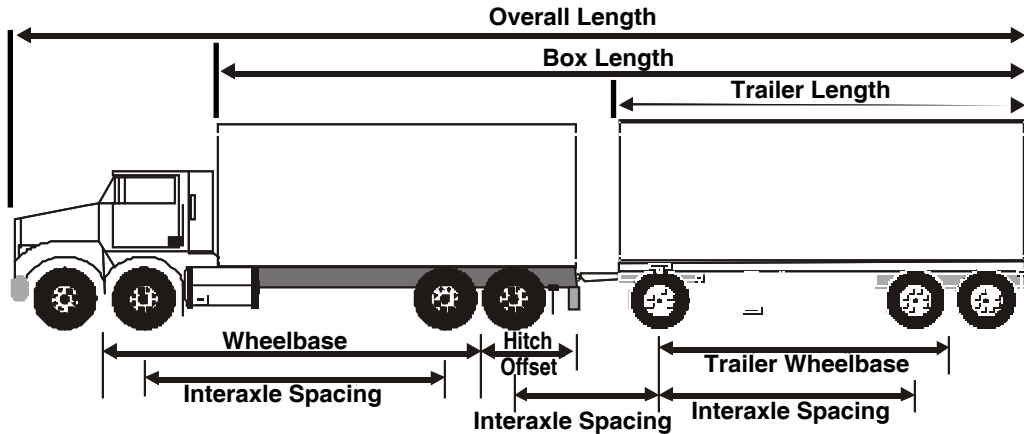
Part 1 – Dimension Limits

DIMENSION	LIMIT
Overall Length	Maximum 23 m
Overall Width	Maximum 2.6 m
Overall Height	Maximum 4.15 m
Box Length	Maximum 20 m
Truck:	
Length	Maximum 12.5 m
Wheelbase	Not controlled
Tandem Axle Group Spread	Minimum 1.0 m/Maximum 1.85 m
Effective Overhang	Maximum 4.0 m
Hitch Offset	Maximum 1.8 m
Full Trailer	
Length	Maximum 12.5 m
Wheelbase	Minimum 6.25 m
Tandem Axle Group Spread	Minimum 1.0 m/Maximum 1.85 m
Track Width	Minimum 2.5 m/Maximum 2.6 m
Interaxle Spacings	
Single Axle to Tandem Axle Group	Minimum 3.0 m
Tandem Axle Group to Tandem Axle Group	Minimum 5.0 m

Configuration 6: Twin Steer Tandem Drive Truck - Full Trailer Combination
The information contained in this schedule applies to all twin steer tandem drive trucks in combination with a full trailer or a semi-trailer and converter dolly..
Part 2 – Weight Limits

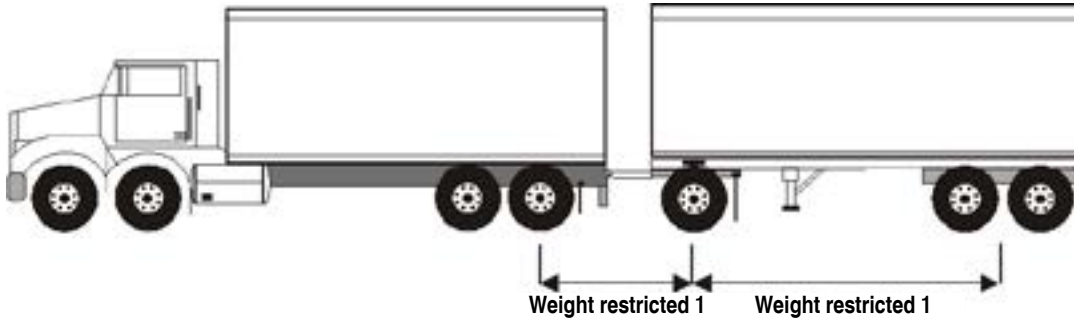

WEIGHT LIMITS		
	Primary Highway	Secondary and Municipal Highways
1) <u>Tandem Steering Axle group</u>	Maximum 13 600 kg	Maximum 11 000 kg
2) <u>Tandem Drive Axle Group</u>	Maximum 17 000 kg	Maximum 14 500 kg
3) <u>Full Trailer Axle Groups</u>		
(a) Single Axle	Maximum 9 100 kg	Maximum 8 200 kg
(b) Tandem Axle Group	Maximum 17 000 kg	Maximum 14 500 kg
4) <u>Full trailer Gross Weights</u> (Note 1)		
Four axle truck, with a		
Two axle trailer	Maximum 17 000 kg	Maximum 16 400 kg
Three axle trailer	Maximum 24 000 kg	Maximum 22 700 kg
Four axle trailer	Maximum 31 000 kg	Maximum 29 000 kg
5) <u>Maximum Gross Vehicle Weights</u>		
Four axle truck, with a		
Two axle trailer	Maximum 47 600 kg	Maximum 41 900 kg
Three axle trailer	Maximum 54 600 kg	Maximum 48 200 kg
Four axle trailer	Maximum 61 600 kg	Maximum 54 500 kg

Weight Restricted 1: Refer to section 17

Note 1 (Weight Restricted 2): The maximum allowable weight on a full trailer is restricted.

Configuration 6: Twin Steer Tandem Drive Truck - Full Trailer Combination (continued)		
<i>WEIGHT LIMITS - Winter Weight Season</i>		
	Primary Highway	Secondary and Municipal Highways
1) <u>Tandem Steering Axle Group</u>	Maximum 13 600 kg	Maximum 11 000 kg
2) <u>Tandem Drive Axle Group</u>	Maximum 18 000 kg	Maximum 18 000 kg
3) <u>Full Trailer Axle Groups</u> (a) Single Axle (b) Tandem Axle Group	Maximum 10 000 kg Maximum 18 000 kg	Maximum 10 000 kg Maximum 18 000 kg
4) <u>Full trailer Gross Weights (Note 1)</u> Four axle truck, with a Two axle trailer Three axle trailer Four axle trailer	Maximum 17 000 kg Maximum 24 000 kg Maximum 31 000 kg	Maximum 17 000 kg Maximum 24 000 kg Maximum 31 000 kg
5) <u>Maximum Gross Vehicle Weights</u> Four axle truck, with a Two axle trailer Three axle trailer Four axle trailer	Maximum 48 600 kg Maximum 55 600 kg Maximum 62 500 kg	Maximum 46 000 kg Maximum 53 000 kg Maximum 54 500 kg

Note 1: The maximum allowable weight on a full trailer is restricted

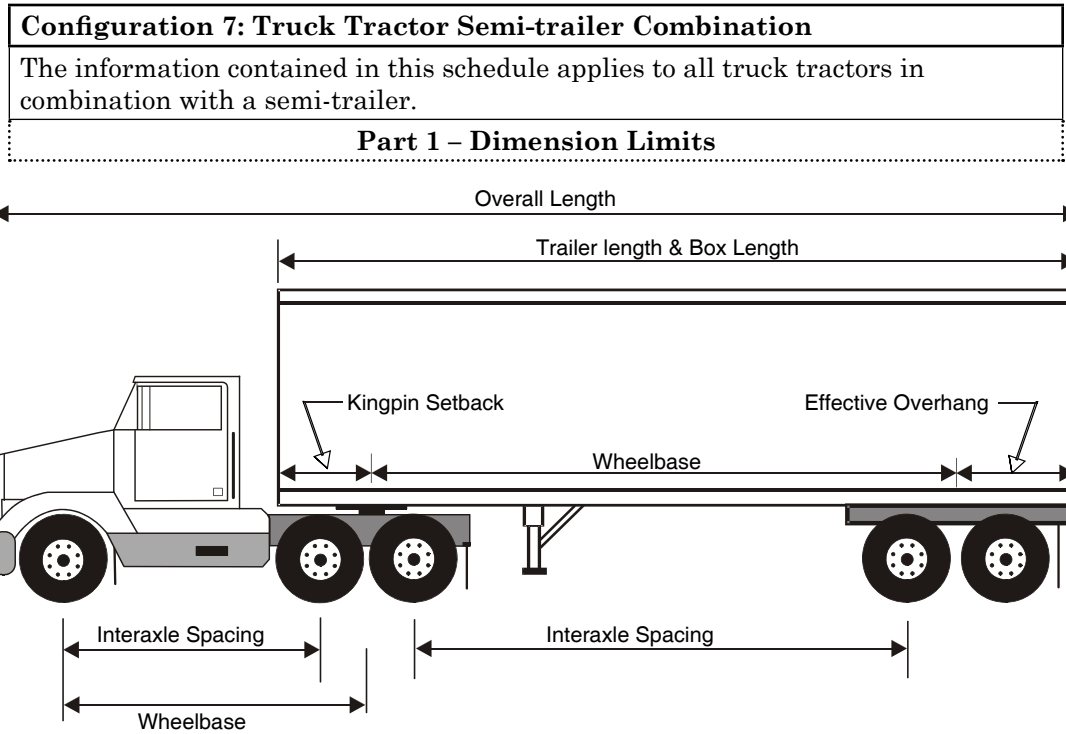

DIMENSION	LIMIT
Overall Length	Maximum 23 m
Overall Width	Maximum 2.6 m
Overall Height	Maximum 4.15 m
Box Length	Maximum 16.2 m
Truck Tractor:	
Wheelbase (Note 1) - Single or Tandem Drive	Maximum 6.2 m (Note 2)
Tandem Axle Group Spread	Minimum 1.0 m/Maximum 3.4 m

Note 1: The wheelbase limit only applies to a truck tractor manufactured after June 30, 1988.

Note 2: The truck tractor wheelbase can be a maximum of 7.2m if the corresponding wheelbase of the semi-trailer is not greater than the limits in the following table:

Truck Tractor Wheelbase (m)	Maximum Semi-Trailer Wheelbase (m)
6.2 or less	12.50 m
> 6.2 to 6.3	12.47 m
> 6.3 to 6.4	12.40
> 6.4 to 6.5	12.33
> 6.5 to 6.6	12.27
> 6.6 to 6.7	12.20
> 6.7 to 6.8	12.13
> 6.8 to 6.9	12.07
> 6.9 to 7.0	12.00
> 7.0 to 7.1	11.93
> 7.1 to 7.2	11.87

Configuration 7: Truck Tractor Semi-trailer Combination (continued)	
DIMENSION	LIMIT
Semi-trailer	
Length	Maximum 16.2 m
Wheelbase Single, Tandem or Tridem Axle Group	Minimum 6.25 m/Maximum 12.5 m
Kingpin Setback	Maximum 2.0 m radius
Effective Overhang (Note 3)	Maximum 35% of wheelbase
Tandem Axle Group Spread	Minimum 1.0 m/Maximum 3.4 m
Tridem Axle Group Spread	Minimum 2.4 m/Maximum 3.7 m
Track Width	Minimum 2.5 m/Maximum 2.6 m
Interaxle Spacings	
Single Axle to Single, Tandem or Tridem Axle Group	Minimum 3.0 m
Tandem Axle Group to Tandem Axle Group	Minimum 5.0 m
Tandem Axle Group to Tridem Axle Group	Minimum 5.5 m

Note 3: The effective overhang limit only applies to a semi-trailer manufactured after June 30, 1988.

Configuration 7: Truck Tractor Semi-trailer Combination

The information contained in this schedule applies to all truck tractors in combination with a semi-trailer.

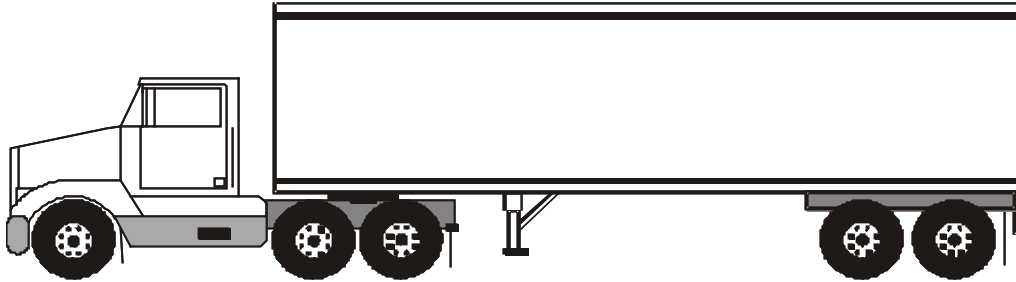
Part 2 – Weight Limits

WEIGHT LIMITS		
	Primary Highway	Secondary and Municipal Highways
1) <u>Steering Axle</u>	Maximum 6 000 kg	Maximum 6 000 kg
2) <u>Drive Axle Group</u>		
(a) Single Axle	Maximum 9 100 kg	Maximum 8 200 kg
(b) Tandem Axle Group	Maximum 17 000 kg	Maximum 14 500 kg
3) <u>Semi-Trailer Axle Group</u>		
(a) Single Axle	Maximum 9 100 kg	Maximum 8 200 kg
(b) Tandem Axle Group	Maximum 17 000 kg	Maximum 14 500 kg
(c) Tridem Axle Group		
(i) Tridem Spread 2.4 m to 3.0 m	Maximum 21 000 kg	Maximum 20 000 kg
(ii) Tridem Spread >3.0 m to 3.6 m	Maximum 23 000 kg	Maximum 20 000 kg
(iii) Tridem Spread >3.0 m to 3.6 m on Highways listed in Appendix E (Note 1)	Maximum 24 000 kg	
(iv) Spread >3.6 m to 3.7 m	Maximum 24 000 kg	Maximum 20 000 kg

Configuration 7: Truck Tractor Semi-trailer Combination (continued)		
<i>WEIGHT LIMITS</i>		
<u>4) Maximum gross vehicle weights</u>		
(a) Two axle truck tractor, single axle trailer	Maximum 24 200 kg	Maximum 22 400 kg
(b) Two axle truck tractor, tandem axle trailer	Maximum 32 100 kg	Maximum 28 700 kg
(c) Three axle truck tractor, single axle trailer	Maximum 32 100 kg	Maximum 28 700 kg
(d) Three axle truck tractor, tandem axle trailer	Maximum 40 000 kg	Maximum 35 000 kg
(e) Three axle truck tractor, tridem axle trailer	Maximum 44 000 kg	Maximum 40 500 kg
(i) Tridem Spread 2.4 m to 3.0 m	Maximum 46 000 kg	Maximum 40 500 kg
(ii) Tridem Spread >3.0 m to 3.6 m	Maximum 47 000 kg	
(iii) Tridem Spread >3.0 m to 3.6 m on Highways listed in Appendix E (Note 2)	Maximum 47 000 kg	Maximum 40 500 kg
(iv) Tridem Spread >3.6 m to 3.7 m		

Note 1: The maximum allowable weight on a tridem axle group on a semi-trailer with a spread greater than 3.0 m up to 3.6 m is 24 000 kg on provincial highways or portions of provincial highways listed in Appendix E.

Note 2: The maximum allowable weight on a three axle truck tractor semi-trailer combination is 47 000 kg on provincial highways or portions of provincial highways listed in Appendix E.

Configuration 7: Truck Tractor Semi-trailer Combination		
<i>WEIGHT LIMITS - Winter Weight Season</i>		
	Primary Highway	Secondary and Municipal Highways
1) <u>Steering Axle</u>	Maximum 6 000 kg	Maximum 6 000 kg
2) <u>Drive Axle Group</u> (a) Single Axle (b) Tandem Axle Group	Maximum 10 000 kg Maximum 18 000 kg	Maximum 10 000 kg Maximum 18 000 kg
3) <u>Semi-Trailer Axle Group</u> (a) Single Axle (b) Tandem Axle Group (c) Tridem Axle Group (i) Tridem Spread 2.4 m to 3.0 m (ii) Tridem Spread >3.0 m to 3.6 m (iii) Tridem Spread >3.0 m to 3.6 m on Highways listed in Appendix E (Note 1) (iv) Tridem Spread >3.6 m to 3.7 m	Maximum 10 000 kg Maximum 18 000 kg Maximum 21 000 kg Maximum 23 000 kg Maximum 24 000 kg Maximum 24 000 kg	Maximum 10 000 kg Maximum 18 000 kg Maximum 21 000 kg Maximum 23 000 kg Maximum 24 000 kg Maximum 24 000 kg
4) <u>Maximum Gross Vehicle Weights</u> (a) Two axle truck tractor, single axle trailer (b) Two axle truck tractor, tandem axle trailer (c) Three axle truck tractor, single axle trailer (d) Three axle truck tractor, tandem axle trailer (e) Three axle truck tractor, tridem axle trailer (i) Tridem Spread 2.4 m to 3.0 m (ii) Tridem Spread >3.0 m to 3.6 m (iii) Tridem Spread >3.0 m to 3.6 m on Highways listed in Appendix E (Note 2) (iv) Tridem Spread >3.6 m to 3.7 m	Maximum 26 000 kg Maximum 34 000 kg Maximum 34 000 kg Maximum 42 000 kg Maximum 45 000 kg Maximum 47 000 kg Maximum 48 000 kg Maximum 48 000 kg	Maximum 26 000 kg Maximum 34 000 kg Maximum 34 000 kg Maximum 42 000 kg Maximum 45 000 kg Maximum 47 000 kg Maximum 48 000 kg Maximum 48 000 kg

Note 1: The maximum allowable weight on a tridem axle group on a semi-trailer with a spread greater than 3.0 m up to 3.6 m is 24 000 kg on provincial highways or portions of provincial highways listed in Appendix E.

Note 2: The maximum allowable weight on a three axle truck tractor semi-trailer combination is 48 000 kg on provincial highways or portions of provincial highways listed in Appendix E.

Configuration 8: A-Train
 The information contained in this schedule applies to all truck tractors in combination with a semi-trailer towing either a full trailer or a semi-trailer with an A-dolly.
Part 1 – Dimension Limits

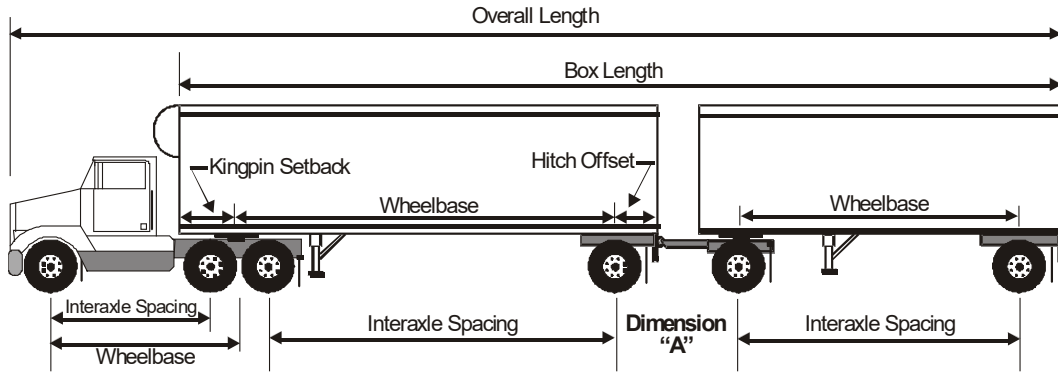

DIMENSION	LIMIT
Overall Length	Maximum 26.0 m
Overall Width	Maximum 2.6 m
Overall Height	Maximum 4.15 m
Box Length	Maximum 20.0 m
Truck Tractor:	
Wheelbase	Maximum 6.2 m
Tandem Axle Group Spread	Minimum 1.0 m/Maximum 1.85 m
Lead Semi-trailer	
Wheelbase	Minimum 6.25 m
Kingpin Setback	Maximum 2.0 m radius
Tandem Axle Group Spread	Minimum 1.0 m/Maximum 3.4 m
Hitch Offset	Maximum 1.8 m
Track Width	Minimum 2.5 m/Maximum 2.6 m

Configuration 8: A-Train (continued)	
DIMENSION	LIMIT
Second Semi-trailer or Full Trailer	
Wheelbase	Minimum 6.25 m
Kingpin Setback	Maximum 2.0 m radius
Tandem Axle Group Spread (Note 1)	Minimum 1.0 m/Maximum 1.85 m
Track Width	Minimum 2.5 m/Maximum 2.6 m
Interaxle Spacings	
Single Axle to Single or Tandem Axle Group	Minimum 3.0 m
Tandem Axle Group to Tandem Axle Group	Minimum 5.0 m
Dimension "A" (from the centre of last axle on the lead semi-trailer to the centre of the first axle on the converter dolly or second trailer)	Not controlled

Note 1: The maximum axle group spread for a Semi-trailer is 3.4 m.

Configuration 8: A-Train
The information contained in this schedule applies to all truck tractors in combination with a semi-trailer towing either a full trailer or a semi-trailer with an A-dolly.
Part 2 - Weight Limits

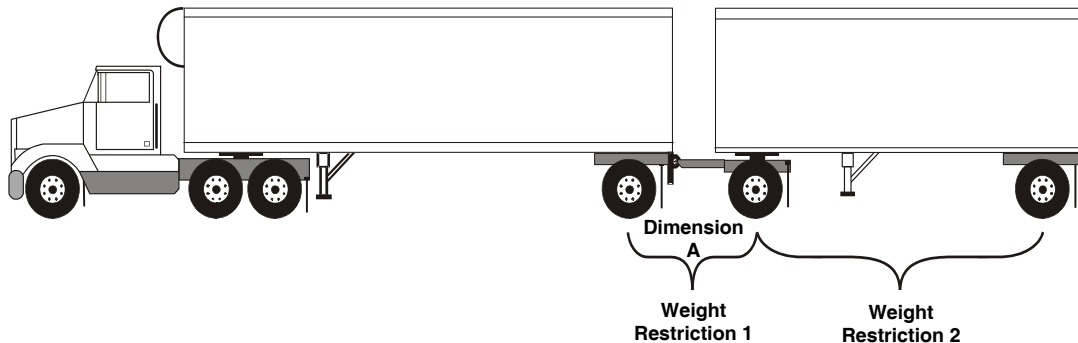

WEIGHT LIMITS		
	Primary Highway	Secondary and Municipal Highways
1) <u>Steering Axle</u>	Maximum 6 000 kg	Maximum 6 000 kg
2) <u>Drive Axle Group</u>		
(a) Single Axle	Maximum 9 100 kg	Maximum 8 200 kg
(b) Tandem Axle Group	Maximum 17 000 kg	Maximum 14 500 kg
3) <u>Semi-Trailer Axle Group(s)</u>		
(a) Single Axle	Maximum 9 100 kg	Maximum 8 200 kg
(b) Tandem Axle Group	Maximum 17 000 kg	Maximum 14 500 kg

Weight Restriction 1: Refer to section 17

Weight Restriction 2: The weight of the second trailer must not exceed the weight of the truck tractor drive axle(s) plus the weight of the axle(s) on the first semi-trailer.

Configuration 8: A-Train (continued)			
WEIGHT LIMITS - Primary Highways			
	Lead Semi-trailer	Second Semi-trailer or Full Trailer (Note 1)	Maximum Gross Vehicle Weight
2 axle truck tractor	Single axle	2 single axles, 1 single axle and 1 tandem axle group, or 2 tandem axle groups	42 400 kg
	Tandem axle group	2 single axles	50 300 kg
	Tandem axle group	1 single axle and 1 tandem axle group, or 2 tandem axle groups	53 500 kg
3 axle truck tractor	Single axle	2 single axles	50 300 kg
	Single axle	1 single axle and 1 tandem axle group, or 2 tandem axle groups	53 500 kg
	Tandem axle group	2 single axles, 1 single axle and 1 tandem axle group, or 2 tandem axle groups	53 500 kg

Note 1: The weight of the second trailer must not exceed the weight of the tractor drive axle(s) plus the weight of the axle(s) on the first semi-trailer.

Configuration 8: A-Train (continued)			
WEIGHT LIMITS - Secondary and Municipal Highways			
	Lead Semi-trailer	Second Semi-trailer or Full Trailer	Maximum Gross Vehicle Weight
2 axle truck tractor	Single axle	2 single axles, 1 single axle and 1 tandem axle group, or 2 tandem axle groups	38 800 kg
	Tandem axle group	2 single axles	45 100 kg
	Tandem axle group	1 single axle and 1 tandem axle group, or 2 tandem axle groups	49 000 kg
3 axle truck tractor	Single axle	2 single axles	45 100 kg
	Single axle	1 single axle and 1 tandem axle group, or 2 tandem axle groups	49 000 kg
	Tandem axle group	2 single axles, 1 single axle and 1 tandem axle group, or 2 tandem axle groups	49 000 kg

Configuration 8: A-Train			
The information contained in this schedule applies to all truck tractors in combination with a semi-trailer towing either a full trailer or a semi-trailer with an A-dolly.			
WEIGHT LIMITS - Winter Weight Season			
	Primary Highway	Secondary and Municipal Highways	
1) Steering Axle	Maximum 6 000 kg	Maximum 6 000 kg	
2) Drive Axle Group (a) Single Axle (b) Tandem Axle Group	Maximum 10 000 kg Maximum 18 000 kg	Maximum 10 000 kg Maximum 18 000 kg	
3) Semi-Trailer Axle Group(s) (a) Single Axle (b) Tandem Axle Group	Maximum 10 000 kg Maximum 18 000 kg	Maximum 10 000 kg Maximum 18 000 kg	
Primary, Secondary and Municipal Highways			
	Lead Semi-trailer	Second Semi-trailer or Full Trailer (Note 1)	Maximum Gross Vehicle Weight
2 axle truck tractor	Single axle	2 single axles, 1 single axle and 1 tandem axle group, or 2 tandem axle groups	46 000 kg
	Tandem axle group	2 single axles, 1 single axle and 1 tandem axle group, or 2 tandem axle groups	53 500 kg
3 axle truck tractor	Single axle	2 single axles	53 000 kg
	Single axle	1 single axle and 1 tandem axle group, or 2 tandem axle groups	53 500 kg
	Tandem axle group	2 single axles, 1 single axle and 1 tandem axle group, or 2 tandem axle groups	53 500 kg

Note 1: The weight of the second trailer must not exceed the weight of the tractor drive axle(s) plus the weight of the axle(s) on the first semi-trailer.

Configuration 9: B-Train

The information contained in this schedule applies to all truck tractors in combination with a semi-trailer towing another semi-trailer attached to a fifth wheel mounted on the rear of the first semi-trailer.

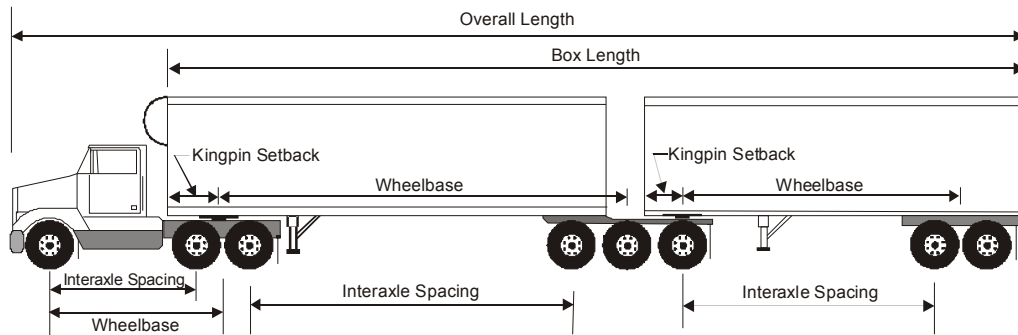
Part 1 - Dimension Limits

DIMENSION	LIMIT
Overall Length (Note 1)	Maximum 27.5 m
Overall Width	Maximum 2.6 m
Overall Height	Maximum 4.15 m
Box Length	Maximum 20.0 m
Tractor:	
Wheelbase	Maximum 6.2 m (Note 2)
Tandem Axle Group Spread	Minimum 1.0 m/Maximum 1.85 m
Lead Semi-trailer	
Wheelbase	Minimum 6.25 m
Kingpin Setback	Maximum 2.0 m radius
Tandem Axle Group Spread	Minimum 1.0 m/Maximum 3.4 m
Tridem Axle Group Spread	Minimum 2.4 m/Maximum 3.1 m
Track Width	Minimum 2.5 m/Maximum 2.6 m
Fifth Wheel Position	No more than 0.3 m behind the centre of the rearmost axle on the semi-trailer

Note 1: The overall length is inclusive of the heavy duty bumper or device designed to reduce the impact of wildlife collisions that is mounted on the front of the truck tractor.

Note 2: The truck tractor wheelbase can be a maximum of 6.8 m if the corresponding sum of the semi-trailer wheelbases is not greater than the limits in the following table:

Tractor Wheelbase (m)	Maximum Sum of Semi-Trailer Wheelbase (m)
6.2 or less	17.00
> 6.2 to 6.3	16.53
> 6.3 to 6.4	16.44
> 6.4 to 6.5	16.36
> 6.5 to 6.6	16.27
> 6.6 to 6.7	16.19
> 6.7 to 6.8	16.10

Configuration 9: B-Train (continued)	
DIMENSION	LIMIT
Second Semi-trailer	
Wheelbase	Minimum 6.25 m
Kingpin Setback	Maximum 2.0 m radius
Tandem Axle Group Spread	Minimum 1.0 m/Maximum 3.4 m
Tridem Axle Group Spread	Minimum 2.4 m/Maximum 3.1 m
Track Width	Minimum 2.5 m/Maximum 2.6 m
Sum of Semi-trailer Wheelbases (Note 3)	Maximum 17.0 m
Interaxle Spacings	
Single Axle to Single, Tandem or Tridem Axle Group	Minimum 3.0 m
Tandem Axle Group to Tandem Axle Group	Minimum 5.0 m
Tandem Axle Group to Tridem Axle Group	Minimum 5.5 m
Tridem Axle Group to Tridem Axle Group	Minimum 6.0 m

Note 3: The sum of semi-trailer wheelbases limit only applies if both semi-trailers were manufactured after December 31, 1991.

Configuration 9: B-Train

The information contained in this schedule applies to all truck tractors in combination with a semi-trailer towing another semi-trailer attached to a fifth wheel mounted on the rear of the first semi-trailer.

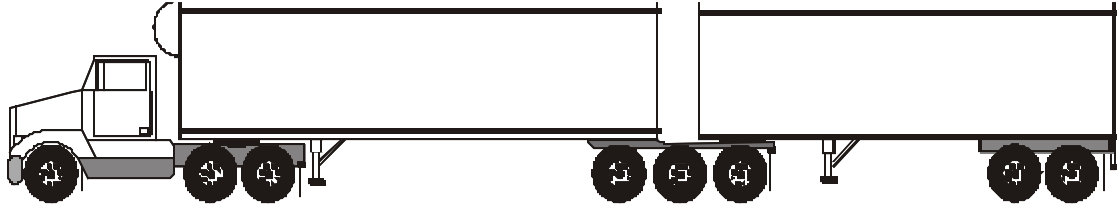
Part 2 - Weight Limits

WEIGHT LIMITS		
	Primary Highway	Secondary and Municipal
1) <u>Steering Axle</u>	Maximum 6 000 kg	Maximum 6 000 kg
2) <u>Drive Axle Group</u>		
(a) Single Axle	Maximum 9 100 kg	Maximum 8 200 kg
(b) Tandem Axle Group	Maximum 17 000 kg	Maximum 14 500 kg
3) <u>Semi-Trailer Axle Group(s)</u>		
(a) Single Axle Group	Maximum 9 100 kg	Maximum 8 200 kg
(b) Tandem Axle Group	Maximum 17 000 kg	Maximum 14 500 kg
(c) Tridem Axle Group		
(i) Tridem Spread 2.4 m to <3.0 m	Maximum 21 000 kg	Maximum 20 000 kg
(ii) Tridem Spread 3.0 m to 3.1 m (Note 1)	Maximum 23 000 kg	Maximum 20 000 kg
(iii) Tridem Spread 3.0 m to 3.1 m on highways listed in Appendix E (Note 2).	Maximum 24 000 kg	

Note 1: The maximum spread on a tridem axle group is 3.1 m

Note 2: The maximum allowable weight on a tridem axle group on a B-train is 24 000 kg on provincial highways or portions of provincial highways listed in Appendix E.

Configuration 9: B-Train			
The information contained in this schedule applies to all truck tractors in combination with a semi-trailer towing another semi-trailer attached to a fifth wheel mounted on the rear of the first semi-trailer.			
Primary Highways			
	Lead Semi-trailer	Second Semi-trailer	Maximum Gross Vehicle Weight
2 axle truck tractor	Tandem axle group	Single axle	41 200 kg
	Tandem axle group	Tandem axle group	49 100 kg
	Tandem axle group	Tridem Axle Group, Spread 2.4 m to <3.0 m	53 100 kg
	Tandem axle group	Tridem Axle Group, Spread 3.0 m to 3.1 m	55 100 kg
	Tandem axle group	Tridem Axle Group, Spread 3.0 m to 3.1 m on highways listed in Appendix E (Note 1)	56 100 kg
	Tridem Axle Group, Spread 2.4 m to <3.0 m	Single axle	45 200 kg
	Tridem Axle Group, Spread 3.0 m to 3.1 m	Single axle	47 200 kg
	Tridem Axle Group, Spread 3.0 m to 3.1 m on highways listed in Appendix E (Note 1)	Single axle	48 200 kg
	Tridem Axle Group, Spread 2.4 m to <3.0 m	Tandem axle group	53 100 kg
	Tridem Axle Group, Spread 3.0 m to 3.1 m	Tandem axle group	55 100 kg
	Tridem Axle Group, Spread 2.4 m to <3.0 m	Tridem Axle Group, Spread 2.4 m to <3.0 m	57 100 kg
	Tridem Axle Group, Spread 2.4 m to <3.0 m	Tridem Axle Group, Spread 3.0 m to 3.1 m	59 100 kg
	Tridem Axle Group, Spread 2.4 m to <3.0 m	Tridem Axle Group, Spread 3.0 m to 3.1 m on highways listed in Appendix E (Note 1)	62 100 kg
	Tridem Axle Group, Spread 3.0 m to 3.1 m	Tridem Axle Group, Spread 3.0 m to 3.1 m	61 100 kg
	Tridem Axle Group, Spread 3.0 m to 3.1 m on highways listed in Appendix E (Note 1)	Tridem Axle Group, Spread 3.0 m to 3.1 m on highways listed in Appendix E (Note 1)	62 500 kg

3 axle truck tractor	Tandem axle group	Single axle	49 100 kg
	Tandem axle group	Tandem axle group	57 000 kg
	Tandem axle group	Tridem Axle Group, Spread 2.4 m to <3.0 m	61 000 kg
	Tandem axle group	Tridem Axle Group, Spread 3.0 m to 3.1 m	62 500 kg
	Tridem Axle Group, Spread 2.4 m to <3.0 m	Tridem Axle Group, Spread 3.0 m to 3.1 m on highways listed in Appendix E (Note 1)	63 500 kg
	Tridem Axle Group, Spread 2.4 m to <3.0 m	Single axle	53 100 kg
	Tridem Axle Group, Spread 3.0 m to 3.1 m	Single axle	55 100 kg
	Tridem Axle Group, Spread 3.0 m to 3.1 m on highways listed in Appendix E (Note 1)	Single axle	56 100 kg
	Tridem Axle Group, Spread 2.4 m to <3.0 m	Tandem axle group	61 000 kg
	Tridem Axle Group, Spread 3.0 m to 3.1 m	Tandem axle group	62 500 kg
	Tridem Axle Group, Spread 3.0 m to 3.1 m on highways listed in Appendix E (Note 1)	Tandem axle group	63 500 kg
	Tridem Axle Group, Spread 2.4 m to 3.1 m	Tridem Axle Group, Spread 2.4 m to 3.1 m	62 500 kg
	Tridem Axle Group, Spread 3.0 m to 3.1 m on highways listed in Appendix E (Note 1)	Tridem Axle Group, Spread 3.0 m to 3.1 m on highways listed in Appendix E (Note 1)	63 500 kg

Note 1: The maximum allowable weight for a B-train is 63 500 kg on provincial highways or portions of provincial highways listed in Appendix E.

Secondary and Municipal Highways			
	Lead Semi-trailer	Second Semi-trailer	Maximum Gross Vehicle Weight
2 axle truck tractor	Tandem axle group	Single axle	36 900 kg
	Tandem axle group	Tandem axle group	43 200 kg
	Tandem axle group	Tridem Axle Group, Spread 2.4 m to 3.1 m	48 700 kg
	Tridem Axle Group, Spread 2.4 m to <3.1 m	Single axle	42 400 kg
	Tridem Axle Group, Spread 2.4 m to 3.1 m	Tandem axle group	48 700 kg
	Tridem Axle Group, Spread 2.4 m to 3.1 m	Tridem Axle Group, Spread 2.4 m to 3.1 m	48 700 kg
3 axle truck tractor	Tandem axle group	Single axle	43 200 kg
	Tandem axle group	Tandem axle group	49 500 kg
	Tandem axle group	Tridem Axle Group, Spread 2.4 m to 3.1 m	54 500 kg
	Tridem Axle Group, Spread 2.4 m to 3.1 m	Single Axle	48 700 kg
	Tridem Axle Group, Spread 2.4 m to 3.1 m	Tandem axle group	54 500 kg
	Tridem Axle Group, Spread 2.4 m to 3.1 m	Tandem axle group	54 500 kg
	Tridem Axle Group, Spread 2.0 m to 3.1 m	Tridem Axle Group, Spread 2.4 m to 3.1 m	54 500 kg

Configuration 9: B-Train		
The information contained in this schedule applies to all truck tractors in combination with a semi-trailer towing another semi-trailer attached to a fifth wheel mounted on the rear of the first semi-trailer.		
WEIGHT LIMITS - Winter Weight Season		
	Primary and Secondary Highways	Municipal Highways
1) Steering Axle	Maximum 6 000 kg	Maximum 6 000 kg
2) Drive Axle Group		
(a) Single Axle	Maximum 10 000 kg	Maximum 10 000 kg
(b) Tandem Axle Group	Maximum 18 000 kg	Maximum 18 000 kg
3) Semi-trailer Axle Group(s)		
(a) Single Axle	Maximum 10 000 kg	Maximum 10 000 kg
(b) Tandem Axle Group	Maximum 18 000 kg	Maximum 18 000 kg
(c) Tridem Axle Group		
(i) Tridem Spread 2.4 m to <3.0 m	Maximum 21 000 kg	Maximum 21 000 kg
(ii) Tridem Spread 3.0 m to 3.1 m	Maximum 23 000 kg	Maximum 23 000 kg
(iii) Tridem Spread 3.0 m to 3.1 m on highways listed in Appendix E (Note 1)	Maximum 24 000 kg	

Note 1: The maximum allowable weight on a tridem axle group on a B-train is 24 000 kg on provincial highways or portions of provincial highways listed in Appendix E.

WEIGHT LIMITS - Winter Weight Season - Primary and Secondary Highways			
	Lead Semi-trailer	Second Semi-trailer	Maximum Gross Vehicle Weight
2 axle truck tractor	Tandem axle group	Single axle	44 000 kg
	Tandem axle group	Tandem axle group	52 000 kg
	Tandem axle group	Tridem Axle Group, Spread 2.4 m to <3.0 m	55 000 kg
	Tandem axle group	Tridem Axle Group, Spread 3.0 m to 3.1 m	57 000 kg

	Tandem axle group	Tridem Axle Group, Spread 3.0 m to 3.1 m on highways listed in Appendix E (Note 1)	58 000 kg
	Tridem Axle Group, Spread 2.4 m to <3.0 m	Single axle	47 000 kg
	Tridem Axle Group, Spread 3.0 m to 3.1 m	Single axle	49 000 kg
	Tridem Axle Group, Spread 3.0 m to 3.1 m on highways listed in Appendix E (Note 1)	Single axle	50 000 kg
	Tridem Axle Group, Spread 2.4 m to <3.0 m	Tandem axle group	55 000 kg
	Tridem Axle Group, Spread 3.0 m to 3.1 m	Tandem axle group	57 000 kg
	Tridem Axle Group, Spread 2.4 m to <3.0 m	Tridem Axle Group, Spread 2.4 m to <3.0 m	58 000 kg
	Tridem Axle Group, Spread 2.4 m to <3.0 m	Tridem Axle Group, Spread 3.0 m to 3.1 m	60 000 kg
	Tridem Axle Group, Spread 2.4 m to <3.0 m	Tridem Axle Group, Spread 3.0 m to 3.1 m on highways listed in Appendix E (Note 1)	61 000 kg
	Tridem Axle Group, Spread 3.0 m to 3.1 m	Tridem Axle Group, Spread 3.0 m to 3.1 m	62 500 kg
	Tridem Axle Group, Spread 3.0 m to 3.1 m on highways listed in Appendix E (Note 1)	Tridem Axle Group, Spread 3.0 m to 3.1 m on highways listed in Appendix E (Note 1)	63 500 kg

3 axle truck tractor	Tandem axle group	Single axle	52 000 kg
	Tandem axle group	Tandem axle group	60 000 kg
	Tandem axle group	Tridem Axle Group, Spread 2.4 m to 3.1 m	62 500 kg
	Tridem Axle Group, Spread 2.4 m to <3.0 m	Single Axle	55 000 kg
	Tridem Axle Group, Spread 3.0 m to 3.1 m	Single Axle	57 000 kg
	Tridem Axle Group, Spread 3.0 m to 3.1 m on highways listed in Appendix E (Note 1)	Single Axle	58 000 kg
	Tridem Axle Group, Spread 2.4 m to <3.0 m	Tandem axle group	62 500 kg
	Tridem Axle Group, Spread 2.4 m to 3.1 m	Tridem Axle Group, Spread 2.4 m to 3.1 m	62 500 kg
	Tridem Axle Group, Spread 3.0 m to 3.1 m on	Tandem axle group	63 500 kg
	Tridem Axle Group, Spread 3.0 m to 3.1 m	Tandem axle group	62 500 kg
	Tridem Axle Group, Spread 3.0 m to 3.1 m on highways listed in Appendix E (Note 1)	Tridem Axle Group, Spread 3.0 m to 3.1 m on highways listed in Appendix E (Note 1)	63 500 kg

Note 1: The maximum allowable weight on a B-train is 63 500 kg on provincial highways or portions of provincial highways listed in Appendix E.

Configuration 9: B-Train (continued)			
<i>WEIGHT LIMITS - Winter Weight Season - Municipal Highways</i>			
	Lead Semi-trailer	Second Semi-trailer	Maximum Gross Vehicle Weight
2 axle truck tractor	Tandem axle group	Single axle	44 000 kg
	Tandem axle group	Tandem axle group	52 000 kg
	Tandem axle group	Tridem Axle Group, Spread 2.4 m to 3.1 m	54 500 kg
	Tridem Axle Group, Spread 2.4 m to <3.0 m	Single Axle	47 000 kg
	Tridem Axle Group, Spread 3.0 m to 3.1 m	Single Axle	49 000 kg
	Tridem Axle Group, Spread 2.4 m to 3.1 m	Tridem Axle Group, Spread 2.4 m to 3.1 m	54 500 kg
	Tridem Axle Group, Spread 2.4 m to 3.1 m	Tandem axle group	54 500 kg
	Tridem Axle Group, Spread 2.4 m to 3.1 m	Tridem Axle Group, Spread 2.4 m to 3.1 m	54 500 kg
3 axle truck tractor	Tandem axle group	Single axle	52 000 kg
	Tandem axle group	Tandem axle group	54 500 kg
	Tandem axle group	Tridem Axle Group, Spread 2.4 m to 3.1 m	54 500 kg
	Tridem Axle Group, Spread 2.4 m to 3.1 m	Single axle	54 500 kg
	Tridem Axle Group, Spread 2.4 m to 3.1 m	Tandem axle group	54 500 kg
	Tridem Axle Group, Spread 2.4 m to 3.1 m	Tridem Axle Group, Spread 2.4 m to 3.1 m	54 500 kg

Configuration 10: C-Train

The information contained in this schedule applies to all truck tractors in combination with a semi-trailer towing another full trailer attached to the first semi-trailer by means of a C-dolly.

Part 1 – Dimension Limits

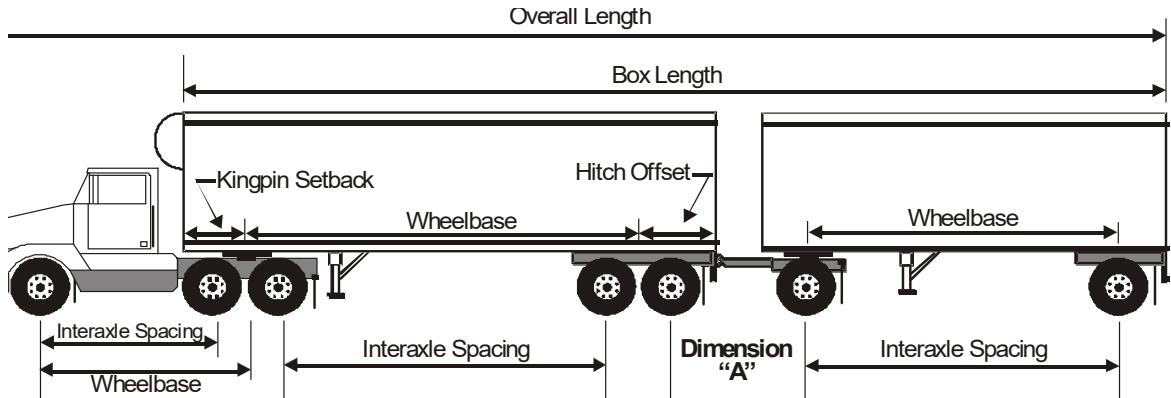

DIMENSION	LIMIT
Overall Length	Maximum 26.0 m
Overall Width	Maximum 2.6 m
Overall Height	Maximum 4.15 m
Box Length	Maximum 20.0 m
Truck Tractor:	
Wheelbase	Maximum 6.2 m
Tandem Axle Group Spread	Minimum 1.0 m/Maximum 1.85 m
Lead Semi-trailer	
Wheelbase	Minimum 6.25 m
Kingpin Setback	Maximum 2.0 m radius
Tandem Axle Group Spread	Minimum 1.0 m/Maximum 3.4 m
Hitch Offset	Maximum 1.8 m
Track Width	Minimum 2.5 m/Maximum 2.6 m

Configuration 10: C-Train	
DIMENSION	LIMIT
Second Semi-trailer or Full Trailer	
Wheelbase	Minimum 6.25 m
Tandem Axle Group Spread (Note 1)	Minimum 1.0 m/Maximum 1.85 m
Track Width	Minimum 2.5 m/Maximum 2.6 m
C-Dolly Drawbar Length	
	Maximum 2.0 m
Interaxle Spacings	
Single Axle to Single Axle or Tandem Axle Group	Minimum 3.0 m
Tandem Axle Group to Tandem Axle Group	Minimum 5.0 m
Dimension "A" (from the centre of last axle on the lead semi-trailer to the centre of the first axle on the converter dolly or second trailer)	Not controlled

Note 1: The maximum axle group spread for a Semi-trailer is 3.4 m.

Configuration 10: C-Train
The information contained in this schedule applies to all truck tractors in combination with a semi-trailer towing another full trailer attached to the first semi-trailer by means of a C-dolly.
Part 2 – Weight Limits

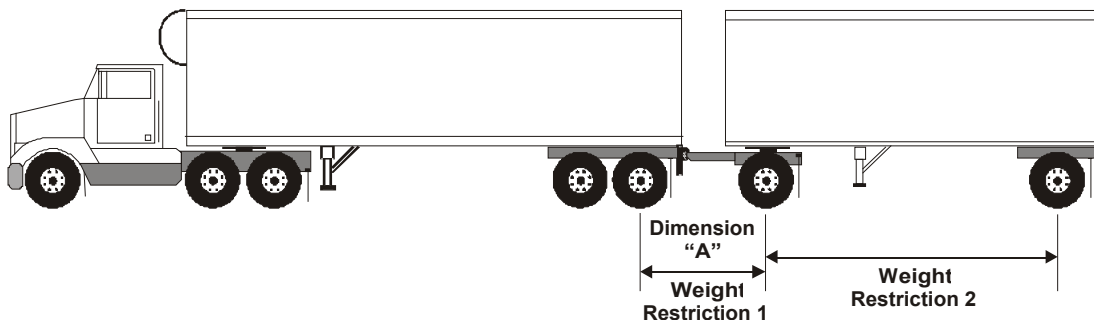

WEIGHT LIMITS		
	Primary Highway	Secondary and Municipal Highways
1) <u>Steering Axle</u>	Maximum 6 000 kg	Maximum 6 000 kg
2) <u>Drive Axle Group</u>		
(a) Single Axle	Maximum 9 100 kg	Maximum 8 200 kg
(b) Tandem Axle Group	Maximum 17 000 kg	Maximum 14 500 kg
3) <u>Semi-Trailer Axle Group(s)</u>		
(a) Single Axle	Maximum 9 100 kg	Maximum 8 200 kg
(b) Tandem Axle Group	Maximum 17 000 kg	Maximum 14 500 kg

Weight Restriction 1: Refer to section 17

Weight Restriction 2: The weight of the second trailer must not exceed the weight of

the truck tractor drive axle(s) plus the weight of the axle(s) on the first semi-trailer.

Configuration 10: C-Train (continued)			
WEIGHT LIMITS - Primary Highways			
	Lead Semi-trailer	Second Semi-trailer or Full Trailer (Note 1)	Maximum Gross Vehicle Weight
2 axle truck tractor	Single axle	2 single axles, or 1 single axle and 1 tandem axle group	42 400 kg
	Tandem axle group	2 single axles	50 300 kg
	Tandem axle group	1 single axle and 1 tandem axle group	58 200 kg
3 axle truck tractor	Single axle	2 single axles	50 300 kg
	Single axle	1 single axle and 1 tandem axle group	58 200 kg
	Tandem axle group	2 single axles	58 200 kg
	Tandem axle group	1 single axle and 1 tandem axle group	60 500 kg

Note 1: The weight of the second trailer must not exceed the weight of the tractor drive axle(s) plus the weight of the axle(s) of the first semi-trailer.

WEIGHT LIMITS - Secondary and Municipal Highways			
	Lead Semi-trailer	Second Semi-trailer or Full Trailer	Maximum Gross Vehicle Weight
2 axle truck tractor	Single axle	2 single axles, or 1 single axle and 1 tandem axle group	38 800 kg
	Tandem axle group	2 single axles	45 100 kg
	Tandem axle group	1 single axle and 1 tandem axle group	51 400 kg
3 axle truck tractor	Single axle	2 single axles	45 100 kg
	Single axle	1 single axle and 1 tandem axle group	51 400 kg
	Tandem axle group	2 single axles	51 400 kg
	Tandem axle group	1 single axle and 1 tandem axle group	55 000 kg

Configuration 10: C-Train		
The information contained in this schedule applies to all truck tractors in combination with a semi-trailer towing another full trailer attached to the first semi-trailer by means of a C-dolly.		
WEIGHT LIMITS - Winter Weight Season		
	Primary Highway	Secondary and Municipal Highways
1) Steering Axle	Maximum 6 000 kg	Maximum 6 000 kg
2) Drive Axle Group		
(a) Single Axle	Maximum 10 000 kg	Maximum 10 000 kg
(b) Tandem Axle Group	Maximum 18 000 kg	Maximum 18 000 kg
3) Semi-Trailer Axle Group(s)		
(a) Single Axle	Maximum 10 000 kg	Maximum 10 000 kg
(b) Tandem Axle Group	Maximum 18 000 kg	Maximum 18 000 kg

WEIGHT LIMITS - Winter Weight Season - Primary Highways			
	Lead Semi-trailer	Second Semi-trailer or Full Trailer (Note 1)	Maximum gross vehicle weight
2 axle truck tractor	Single axle	2 single axles, or 1 single axle and 1 tandem axle group	46 000 kg
	Tandem axle group	2 single axles	54 000 kg
	Tandem axle group	1 single axle and 1 tandem axle group	60 500 kg
3 axle truck tractor	Single axle	2 single axles	53 000 kg
	Single axle	1 single axle and 1 tandem axle group	60 500 kg
	Tandem axle group	2 single axles	60 500 kg
	Tandem axle group	1 single axle and 1 tandem axle group	60 500 kg

Note 1: The weight of the second trailer must not exceed the weight of the tractor drive axle(s) plus the weight of the axle(s) on the first semi-trailer

Configuration 10: C-Train (continued)			
WEIGHT LIMITS - Winter Weight Season - Secondary and Municipal Highways			
	Lead Semi-trailer	Second Semi-trailer or Full Trailer (Note 1)	Maximum gross vehicle weight
2 axle truck tractor	Single axle	2 single axles, or 1 single axle and 1 tandem axle group	46 000 kg
	Tandem axle group	2 single axles	54 000 kg
	Tandem axle group	1 single axle and 1 tandem axle group	54 500 kg
3 axle truck tractor	Single axle	2 single axles	53 000 kg
	Single axle	1 single axle and 1 tandem axle group	54 500 kg
	Tandem axle group	2 single axles	54 500 kg
	Tandem axle group	1 single axle and 1 tandem axle group	54 500 kg

Configuration 11: Intercity Bus and Recreational Vehicles
The information contained in this schedule applies to all buses and recreational vehicles.
Part 1 – Dimension Limits

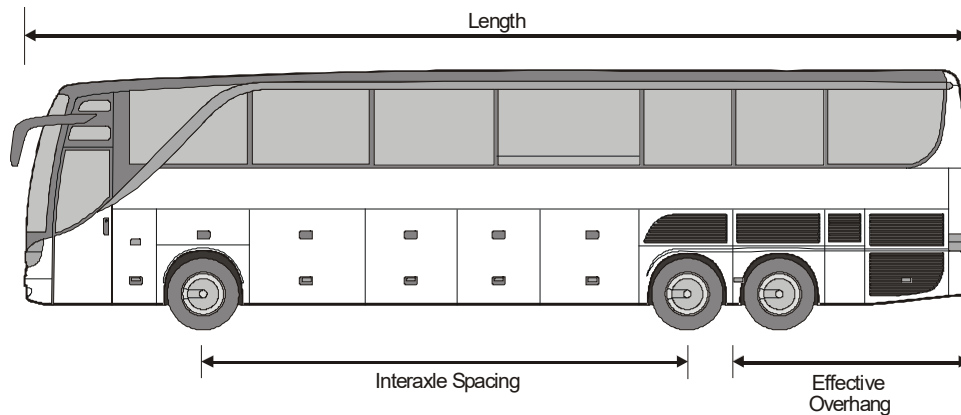

DIMENSION	LIMIT
Overall Length	Maximum 14.0 m
Overall Width	Maximum 2.6 m
Overall Height	Maximum 4.15 m
Wheelbase	Not controlled
Tandem Axle Spread	Minimum 1.2 m/Maximum 1.85 m
Effective Overhang	Maximum 4.0 m

Axle Requirements:	
Overall length 12.5 m or less	Not controlled
Overall length greater than 12.5 m	Minimum 3 axles

Configuration 11: Intercity Bus and Recreational Vehicles
The information contained in this schedule applies to all buses and recreational vehicles.
Part 2 – Weight Limits

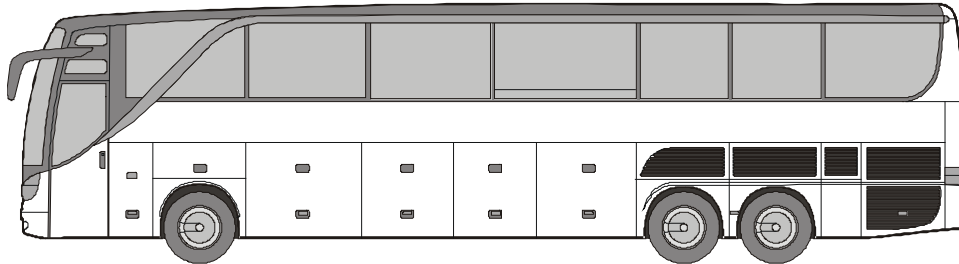

<i>WEIGHT LIMITS</i>	
1) <u>Steering Axle</u>	Maximum 7 300 kg
2) <u>Drive Axle Group</u>	
(a) Single Axle (single tires)	Maximum 6 000 kg
(b) Single Axle (dual tires)	Maximum 9 100 kg
(c) Single Half Axle Unit	Maximum 15 100 kg
(d) Tandem Axle Group	Maximum 17 000 kg
3) <u>Maximum Gross Vehicle Weights, single steer with:</u>	
(a) Single Drive Axle with single tires	13 300 kg
(b) Single Drive Axle with dual tires	16 400 kg
(c) Single-Half Axle Unit (2 drive axles, one with single tires and one with dual tires)	22 400 kg
(d) Tandem Drive Axle Group, both with dual tires	24 300 kg

Configuration 12: Tridem Drive Straight Truck

The information contained in this schedule applies to all trucks equipped with a single steering axle and a tridem drive axle group.

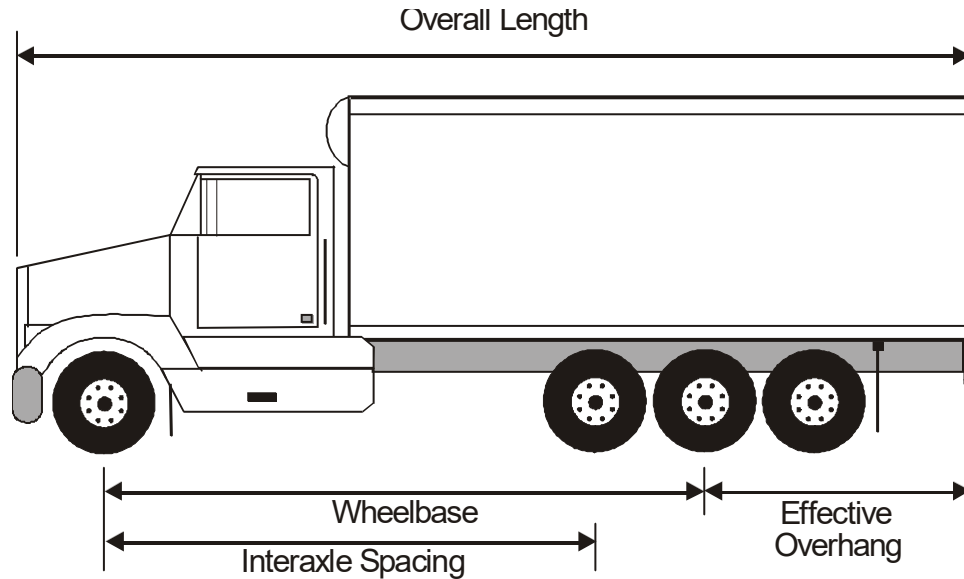
Part 1 - Dimension Limits

DIMENSION	LIMIT
Overall Length	Maximum 12.5 m
Overall Width	Maximum 2.6 m
Overall Height	Maximum 4.15 m
Truck	
Wheelbase	Minimum 6.6 m
Tridem Drive Axle Spread (Note 1)	Minimum 2.4 m/Maximum 2.8 m
Track Width	Minimum 2.5 m/Maximum 2.6 m
Effective Overhang	Maximum 4.0 m

Note 1: All three axles in tridem group must drive (no pusher, tag or lift axles allowed). Drive axle locking devices must be unlocked while operating on a public highway.

Configuration 12: Tridem Drive Straight Truck (continued)
Part 2 – Weight Limits

<i>WEIGHT LIMITS</i>		
	Primary Highway	Secondary and Municipal Highways
1) <u>Steering Axle</u>	Minimum 27% of drive axles at all times to a maximum 7 300 kg	Minimum 27% of drive axles at all times to a maximum 7 300 kg
2) <u>Tridem Drive Axle Group</u>		
(a) Axle Spread 2.4 m to <2.7 m	Maximum 21 000 kg	Maximum 20 000 kg
(b) Axle Spread 2.7 m to 2.8 m	Maximum 22 000 kg	Maximum 20 000 kg
3) <u>Maximum Gross Vehicle Weights</u>		
(a) Axle Spread 2.4 m to <2.7 m	Maximum 28 300 kg	Maximum 27 300 kg
(b) Axle Spread 2.7 m to 2.8 m	Maximum 29 300 kg	Maximum 27 300 kg

<i>WEIGHT LIMITS - Winter Weight Season</i>		
	Primary Highway	Secondary and Municipal Highways
1) <u>Steering Axle</u>	Minimum 27% of drive axles at all times to a maximum 7 300 kg	Minimum 27% of drive axles at all times to a maximum 7 300 kg
2) <u>Tridem Drive Axle Group</u>		
(a) Axle Spread 2.4 m to <2.7 m	Maximum 21 000 kg	Maximum 21 000 kg
(b) Axle Spread 2.7 m to 2.8 m	Maximum 22 000 kg	Maximum 21 000 kg
3) <u>Maximum Gross Vehicle Weights</u>		
(a) Axle Spread 2.4 m to <2.7 m	Maximum 28 300 kg	Maximum 28 300 kg
(b) Axle Spread 2.7 m to 2.8 m	Maximum 29 300 kg	Maximum 28 300 kg

Tridem drive trucks are not allowed to tow a full trailer.

Configuration 13: Tridem Drive Truck - Pony Trailer Combination

The information contained in this schedule applies to all trucks equipped with a single steering axle and a tridem drive axle group in combination with a pony trailer.

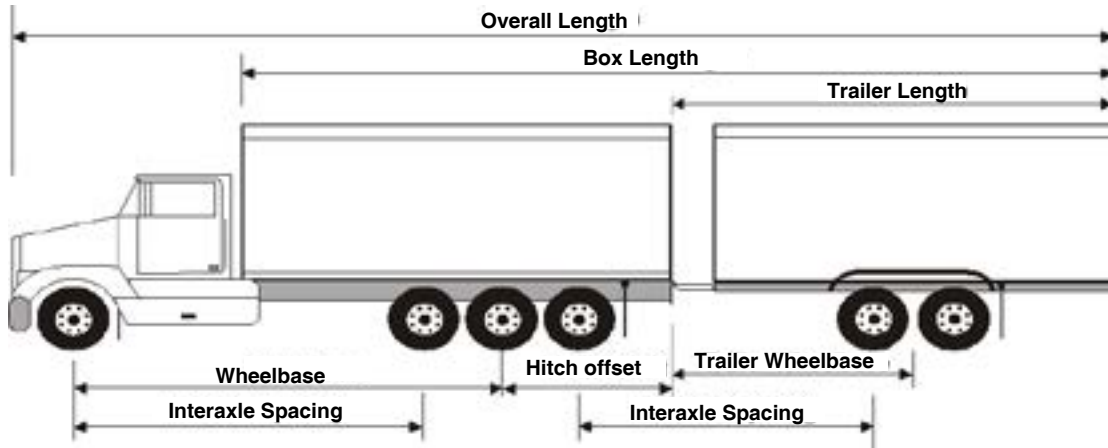
Part 1 - Dimension Limits

DIMENSION	LIMIT
Overall Length	Maximum 23.0 m
Overall Width	Maximum 2.6 m
Overall Height	Maximum 4.15 m
Box Length	Maximum 20.5 m
Truck	
Wheelbase	Minimum 6.6 m
Tridem Drive Axle Spread (Note 1)	Minimum 2.4 m/Maximum 2.8 m
Track Width	Minimum 2.5 m/Maximum 2.6 m
Effective Overhang	Maximum 4.0 m
Hitch Offset	Maximum 2.6 m

Note 1: All three axles in tridem group must drive (no pusher, tag or lift axles allowed). Drive axle locking devices must be unlocked while operating on a public highway.

Configuration 13: Tridem Drive Truck - Pony Trailer Combination
(continued)

DIMENSION	LIMIT
Pony Trailer	
Length	Maximum 12.5 m
Wheelbase (Note 2)	Minimum 6.25 m
Tandem Axle Group Spread (Note 2)	Minimum 1.0 m/Maximum 1.85 m
Tridem Axle Group Spread (Note 2)	Minimum 2.4 m/Maximum 2.5 m
Track Width (Note 2)	Minimum 2.5 m/Maximum 2.6 m
Effective Overhang (Note 2) (Note 3)	Maximum 4.0 m

H-3.01 REG 8 VEHICLE WEIGHT AND DIMENSION, 2010

Interaxle Spacings	
Single Axle to Tridem Axle Group	Minimum 3.0 m
Tandem Axle Group to Tridem Axle Group	Minimum 5.5 m
Tridem Axle Group to Tridem Axle Group	Minimum 6.0 m

Note 2: Does not apply to a pony trailer with a Gross Vehicle Weight Rating of less than 10 000 kg.

Note 3: The maximum effective overhang of 4.0 m applies to a pony trailer manufactured after June 30, 1988. For a pony trailer manufactured before July 1, 1988, the load is restricted to an effective overhang of 4.0 m or the rear of the trailer, whichever is greater.

Configuration 13: Tridem Drive Truck - Pony Trailer Combination
The information contained in this schedule applies to all trucks equipped with a single steering axle and a tridem drive axle group in combination with a pony trailer.
Part 2 - Weight Limits

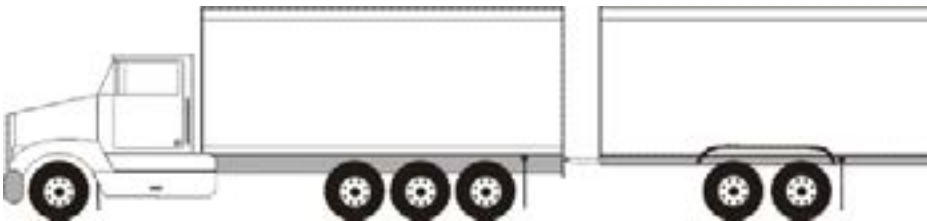

WEIGHT LIMITS		
	Primary Highway	Secondary and Municipal Highways
1) <u>Steering Axle</u>	Minimum 27% of drive axles at all times to a maximum 7 300 kg	Minimum 27% of drive axles at all times to a maximum 7 300 kg
2) <u>Tridem Drive Axle Group</u>		
(a) Axle Spread 2.4 m to <2.7 m	Maximum 21 000 kg	Maximum 20 000 kg
(b) Axle Spread 2.7 m to 2.8 m	Maximum 22 000 kg	Maximum 20 000 kg
3) <u>Pony Trailer with a single axle</u>		
(a) Wheelbase 6.25 m to 7.50 m	Maximum 7 200 kg	Maximum 7 200 kg
(b) Wheelbase >7.50 m	Maximum 7 700 kg	Maximum 7 700 kg

4) <u>Pony Trailer with a tandem axle group</u>		
(a) Wheelbase 6.25 m to 7.50 m	Maximum 11 000 kg	Maximum 11 000 kg
(b) Wheelbase >7.50 m	Maximum 12 000 kg	Maximum 12 000 kg
5) <u>Pony Trailer with a tridem axle group</u>		
(a) Wheelbase 6.25 m to 7.50 m	Maximum 15 000 kg	Maximum 15 000 kg
(b) Wheelbase >7.50 m	Maximum 16 500 kg	Maximum 16 500 kg

WEIGHT LIMITS (continued)		
	Primary Highway	Secondary and Municipal Highways
6) <u>Maximum Gross Vehicle Weights Truck axle group spread 2.4 m to <2.7 m</u>		
(a) pony trailer with single axle		
(i) Wheelbase 6.25 m to 7.50 m	Maximum 35 500 kg	Maximum 34 500 kg
(ii) Wheelbase >7.50 m	Maximum 36 000 kg	Maximum 35 000 kg
(b) pony trailer with a tandem axle group		
(i) Wheelbase 6.25 m to 7.50 m	Maximum 39 300 kg	Maximum 38 300 kg
(ii) Wheelbase >7.50 m	Maximum 40 300 kg	Maximum 39 300 kg
(c) pony trailer with a tridem axle group		
(i) Wheelbase 6.25 m to 7.50 m	Maximum 43 300 kg	Maximum 42 300 kg
(ii) Wheelbase >7.50 m	Maximum 44 800 kg	Maximum 43 800 kg

H-3.01 REG 8**VEHICLE WEIGHT AND DIMENSION, 2010**

7) <u>Maximum Gross Vehicle Weights Truck axle group spread 2.7 m to 2.8 m</u>		
(a) pony trailer with single axle		
(i) Wheelbase 6.25 m to 7.50 m	Maximum 36 500 kg	Maximum 34 500 kg
(ii) Wheelbase >7.50 m	Maximum 37 000 kg	Maximum 35 000 kg
(b) pony trailer with a tandem axle group		
(i) Wheelbase 6.25 m to 7.50 m	Maximum 40 300 kg	Maximum 38 300 kg
(ii) Wheelbase >7.50 m	Maximum 41 300 kg	Maximum 39 300 kg
(c) pony trailer with a tridem axle group		
(i) Wheelbase 6.25 m to 7.50 m	Maximum 44 300 kg	Maximum 42 300 kg
(ii) Wheelbase >7.50 m	Maximum 45 800 kg	Maximum 43 800 kg

<i>WEIGHT LIMITS - Winter Weight Season</i>		
	Primary and Secondary Highways	Municipal Highways
1) <u>Steering Axle</u>	Minimum 27% of drive axles at all times to a maximum 7 300 kg	Minimum 27% of drive axles at all times to a maximum 7 300 kg
2) <u>Tridem Drive Axle Group</u>		
(a) Axle Spread 2.4 m to <2.7 m	Maximum 21 000 kg	Maximum 21 000 kg
(b) Axle Spread 2.7 m to 2.8 m	Maximum 22 000 kg	Maximum 21 000 kg
3) <u>Pony Trailer with a single axle</u>		
(a) Wheelbase 6.25 m to 7.50 m	Maximum 7 200 kg	Maximum 7 200 kg
(b) Wheelbase >7.50 m	Maximum 7 700 kg	Maximum 7 700 kg
4) <u>Pony Trailer with a tandem axle group</u>		
(a) Wheelbase 6.25 m to 7.50 m	Maximum 11 000 kg	Maximum 11 000 kg
(b) Wheelbase >7.50 m	Maximum 12 000 kg	Maximum 12 000 kg

5) <u>Pony Trailer with a tridem axle group</u> (a) Wheelbase 6.25 m to 7.50 m (b) Wheelbase >7.50 m	Maximum 15 000 kg Maximum 16 500 kg	Maximum 15 000 kg Maximum 16 500 kg
6) <u>Maximum Gross Vehicle Weights Truck axle group spread 2.4 m to <2.7 m</u> (a) pony trailer with single axle (i) Wheelbase 6.25 m to 7.50 m (ii) Wheelbase >7.50 m (b) pony trailer with a tandem axle group (i) Wheelbase 6.25 m " to 7.50 m (ii) Wheelbase >7.50 m (c) pony trailer with a tridem axle group (i) Wheelbase 6.25 m to 7.50 m (ii) Wheelbase >7.50 m	Maximum 35 500 kg Maximum 36 000 kg Maximum 39 300 kg Maximum 40 300 kg Maximum 43 300 kg Maximum 44 800 kg	Maximum 35 500 kg Maximum 36 000 kg Maximum 39 300 kg Maximum 40 300 kg Maximum 43 300 kg Maximum 44 800 kg

<i>WEIGHT LIMITS - Winter Weight Season</i> (continued)		
7) <u>Maximum Gross Vehicle Weights Truck axle group spread 2.7 m to 2.8 m</u> (a) pony trailer with single axle (i) Wheelbase 6.25 m to 7.50 m (ii) Wheelbase >7.50 m (b) pony trailer with a tandem axle group (i) Wheelbase 6.25 m to 7.50 m (ii) Wheelbase >7.50 m (c) pony trailer with a tridem axle group (i) Wheelbase 6.25 m to 7.50 m (ii) Wheelbase >7.50 m	Maximum 36 500 kg Maximum 37 000 kg Maximum 40 300 kg Maximum 41 300 kg Maximum 44 300 kg Maximum 45 800 kg	Maximum 35 500 kg Maximum 36 000 kg Maximum 39 300 kg Maximum 40 300 kg Maximum 43 300 kg Maximum 44 800 kg

Configuration 14: Tandem Steer Tridem Drive Straight Truck
The information contained in this schedule applies to all trucks equipped with a tandem steering axle and a tridem drive axle group.
Part 1 - Dimension Limits

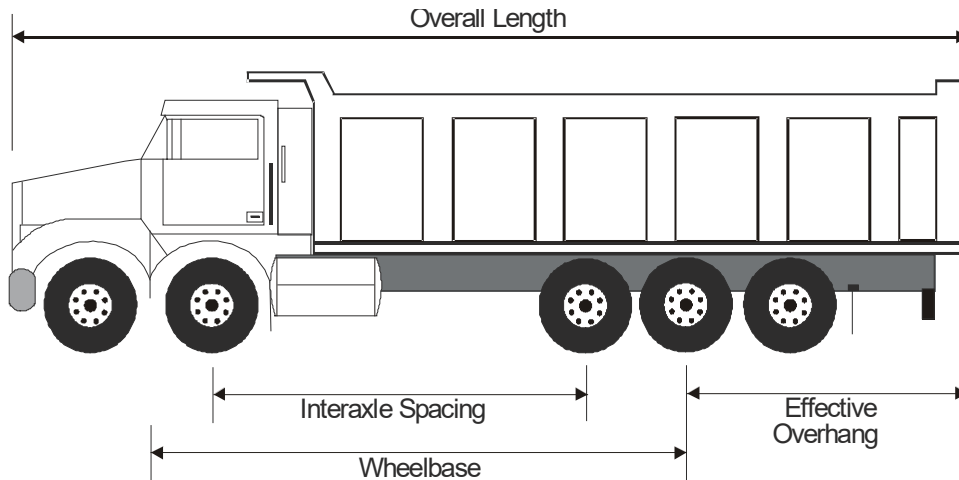

DIMENSION	LIMIT
Overall Length	Maximum 14.0 m
Overall Width	Maximum 2.6 m
Overall Height	Maximum 4.15 m
Truck:	
Wheelbase (Note 1)	Minimum 7.7 m
Tandem Steering Axle Group Spread	Minimum 1.0 m/Maximum 1.85 m
Tridem Drive Axle Group Spread (Note 2)	Minimum 2.4 m/Maximum 3.1 m
Track Width	Minimum 2.5 m/Maximum 2.6 m
Effective Overhang	Maximum 4.0 m

Tridem drive trucks are not allowed to tow a full trailer.

Note 1: Axle spreads and minimum wheelbase conform to the following:

Tridem Drive Axle Spread (m)	Minimum Wheelbase (m)
2.4 – <2.8	7.7
2.8 – <3.0	7.8
3.0 - 3.1	7.9

Note 2: All three axles in tridem drive axle group must drive (no pusher, tag or lift axles allowed). Drive axle locking devices must be unlocked while operating on a highway.

Configuration 14: Tandem Steer Tridem Drive Straight Truck

The information contained in this schedule applies to all trucks equipped with a tandem steering axle and a tridem drive axle group.

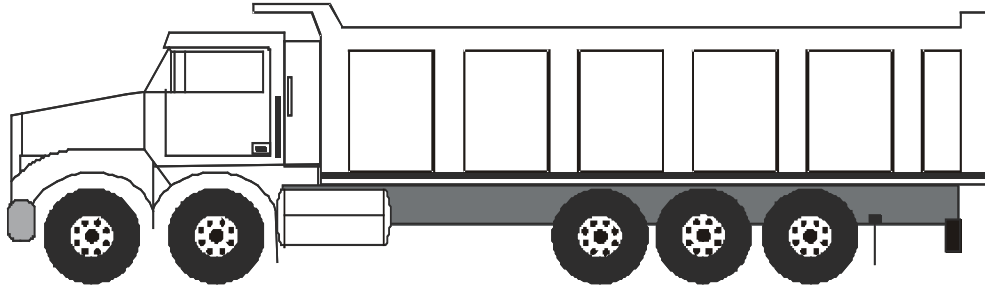
Part 2 – Weight Limits

WEIGHT LIMITS		
	Primary Highway	Secondary and Municipal Highways
1) <u>Tandem Steering Axle Group</u>	Minimum 40% of drive axles at all times to a maximum 13 600 kg	Minimum 40% of drive axles at all times to a maximum 11 000 kg
2) <u>Tridem Drive Axle Group</u>		
(a) Axle Spread 2.4 m to <2.7 m	Maximum 21 000 kg	Maximum 20 000 kg
(b) Axle Spread 2.7 m to <3.0 m	Maximum 22 000 kg	Maximum 20 000 kg
(c) Axle Spread 3.0 m to 3.1 m	Maximum 23 000 kg	Maximum 20 000 kg
3) <u>Maximum Gross Vehicle Weights</u>		
(a) Axle Spread 2.4 m to <2.7 m	Maximum 34 600 kg	Maximum 31 000 kg
(b) Axle Spread 2.7 m to <3.0 m	Maximum 35 600 kg	Maximum 31 000 kg
(c) Axle Spread 3.0 m to 3.1 m	Maximum 36 600 kg	Maximum 31 000 kg
WEIGHT LIMITS - Winter Weight Season		
	Primary Highway	Secondary and Municipal Highways
1) <u>Tandem Steering Axle Group</u>	Minimum 40% of drive axles at all times to a maximum 13 600 kg	Minimum 40% of drive axles at all times to a maximum 11 000 kg
2) <u>Tridem Drive Axle Group</u>		
(a) Axle Spread 2.4 m to <2.7 m	Maximum 21 000 kg	Maximum 21 000 kg
(b) Axle Spread 2.7 m to <3.0 m	Maximum 22 000 kg	Maximum 21 000 kg
(c) Axle Spread 3.0 m to 3.1 m	Maximum 23 000 kg	Maximum 23 000 kg
3) <u>Maximum Gross Vehicle Weights</u>		
(a) Axle Spread 2.4 m to <2.7 m	Maximum 34 600 kg	Maximum 32 000 kg
(b) Axle Spread 2.7 m to <3.0 m	Maximum 35 600 kg	Maximum 32 000 kg
(c) Axle Spread 3.0 m to 3.1 m	Maximum 36 600 kg	Maximum 34 000 kg

Configuration 15: Tandem Steer Tridem Drive Straight Truck - Pony Trailer Combination

The information contained in this schedule applies to all trucks equipped with a tandem steering axle and a tridem drive axle group in combination with a pony trailer.

Part 1 - Dimension Limits

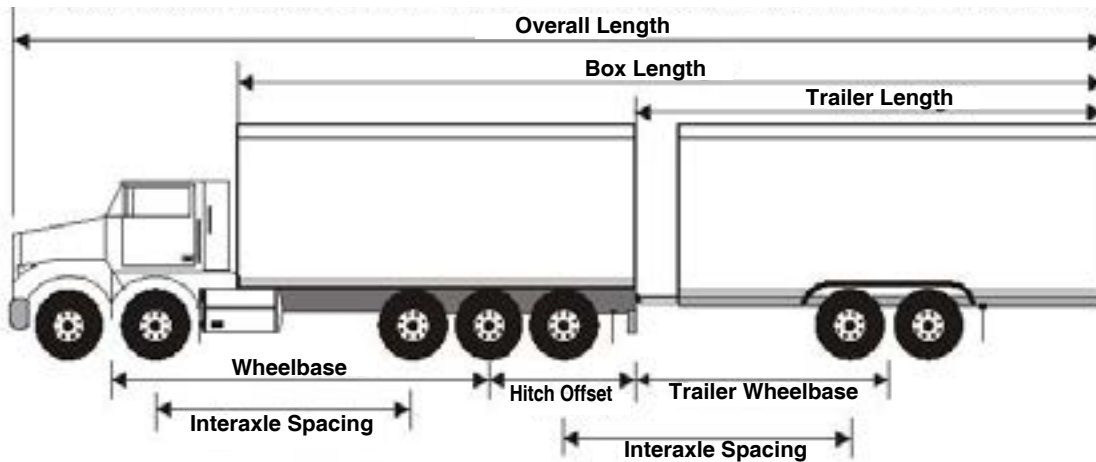

DIMENSION	LIMIT
Overall Length	Maximum 23.0 m
Overall Width	Maximum 2.6 m
Overall Height	Maximum 4.15 m
Box Length	Maximum 21.0 m
Truck:	
Wheelbase (Note 1)	Minimum 7.7 m
Tandem Steering Axle Group Spread	Minimum 1.0 m/Maximum 1.85 m
Tridem Drive Axle Group Spread (Note 2)	Minimum 2.4 m/Maximum 3.1 m
Track Width	Minimum 2.5 m/Maximum 2.6 m
Effective Overhang	Maximum 4.0 m
Hitch Offset	2.6 m

Note 1: Axle spreads and minimum wheelbase must conform to the following:

Tridem Drive Axle Group Spread (m)	Minimum Wheelbase (m)
2.4 - <2.8	7.7
2.8 - <3.0	7.8
3.0 - 3.1	7.9

Note 2: All three axles in tridem drive axle group must drive (no pusher, tag or lift axles allowed). Drive axle locking devices must be unlocked while operating on a highway.

Configuration 15: Tandem Steer Tridem Drive Straight Truck - Pony Trailer Combination (continued)	
DIMENSION	LIMIT
Pony Trailer	
Length	Maximum 12.5 m
Wheelbase (Note 3)	Minimum 6.25 m
Tandem Axle Group Spread (Note 3)	Minimum 1.0 m/Maximum 1.85 m
Tridem Axle Group Spread (Note 3)	Minimum 2.4 m/Maximum 2.5 m
Track Width (Note 3)	Minimum 2.5 m/Maximum 2.6 m
Effective Overhang (Note 3) (Note 4)	Maximum 4.0 m
Interaxle Spacings	
Single Axle to Tridem Axle Group	Minimum 3.0 m
Tandem Axle Group to Tridem Axle Group	Minimum 5.5 m
Tridem Axle Group to Tridem Axle Group	Minimum 6.0 m

Note 3: Does not apply to a pony trailer with a Gross Vehicle Weight Rating of less than 10 000 kg.

Note 4: The maximum effective overhang of 4.0 m applies to a pony trailer manufactured after June 30, 1988. For a pony trailer manufactured before July 1, 1988, the load is restricted to an effective overhang of 4.0 m or the rear of the trailer, whichever is greater.

Configuration 15: Tandem Steer Tridem Drive Straight Truck - Pony Trailer Combination

The information contained in this schedule applies to all trucks equipped with a tandem steering axle and a tridem drive axle group in combination with a pony trailer.

Part 2 - Weight Limits

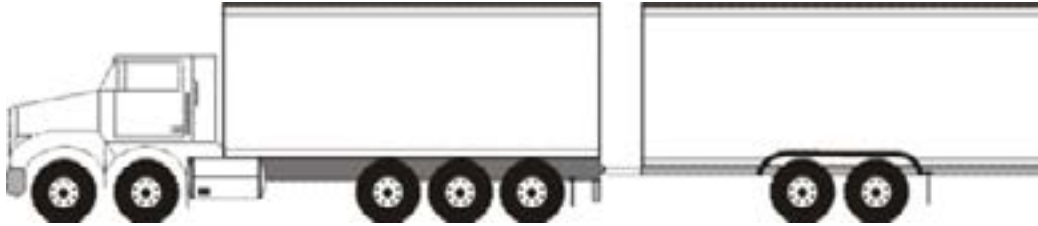

WEIGHT LIMITS		
	Primary Highway	Secondary and Municipal Highways
1) <u>Tandem Steering Axle Group</u>	Minimum 40% of drive axles at all times to a maximum 13 600 kg	Minimum 40% of drive axles at all times to a maximum 11 000 kg
2) <u>Tridem Drive Axle Group</u>		
(a) Axle Spread 2.4 m to <2.7 m	Maximum 21 000 kg	Maximum 20 000 kg
(b) Axle Spread 2.7 m to <3.0 m	Maximum 22 000 kg	Maximum 20 000 kg
(c) Axle Spread 3.0 m to 3.1 m	Maximum 23 000 kg	Maximum 20 000 kg
3) <u>Pony Trailer with a single axle</u>		
(a) Wheelbase 6.25 m to 7.50 m	Maximum 7 200 kg	Maximum 7 200 kg
(b) Wheelbase >7.50 m	Maximum 7 700 kg	Maximum 7 700 kg
4) <u>Pony Trailer with a tandem axle group</u>		
(a) Wheelbase 6.25 m to 7.50 m	Maximum 11 000 kg	Maximum 11 000 kg
(b) Wheelbase >7.50 m	Maximum 12 000 kg	Maximum 12 000 kg
5) <u>Pony Trailer with a tridem axle group</u>		
(a) Wheelbase 6.25 m to 7.50 m	Maximum 15 000 kg	Maximum 15 000 kg
(b) Wheelbase >7.50 m	Maximum 16 500 kg	Maximum 16 500 kg

<i>WEIGHT LIMITS</i> - (continued)		
<p>6) <u>Maximum Gross Vehicle Weights Truck axle group spread 2.4 m to <2.7 m</u></p> <p>(a) pony trailer with single axle</p> <p>(i) Wheelbase 6.25 m to 7.50 m</p> <p>(ii) Wheelbase >7.50 m</p> <p>(b) pony trailer with a tandem axle group</p> <p>(i) Wheelbase 6.25 m to 7.50 m</p> <p>(ii) Wheelbase >7.50 m</p> <p>(c) pony trailer with a tridem axle group</p> <p>(i) Wheelbase 6.25 m to 7.50 m</p> <p>(ii) Wheelbase >7.50 m</p>	<p>Maximum 41 800 kg</p> <p>Maximum 42 300 kg</p> <p>Maximum 45 600 kg</p> <p>Maximum 46 600 kg</p> <p>Maximum 49 600 kg</p> <p>Maximum 51 100 kg</p>	<p>Maximum 38 200 kg</p> <p>Maximum 38 700 kg</p> <p>Maximum 42 000 kg</p> <p>Maximum 43 000 kg</p> <p>Maximum 46 000 kg</p> <p>Maximum 47 500 kg</p>
<p>7) <u>Maximum Gross Vehicle Weights Truck axle group spread 2.4 m to <3.0 m</u></p> <p>(a) pony trailer with single axle</p> <p>(i) Wheelbase 6.25 m to 7.50 m</p> <p>(ii) Wheelbase >7.50 m</p> <p>(b) pony trailer with a tandem axle group</p> <p>(i) Wheelbase 6.25 m to 7.50 m</p> <p>(ii) Wheelbase >7.50 m</p> <p>(c) pony trailer with a tridem axle group</p> <p>(i) Wheelbase 6.25 m to 7.50 m</p> <p>(ii) Wheelbase >7.50 m</p>	<p>Maximum 42 800 kg</p> <p>Maximum 43 300 kg</p> <p>Maximum 46 600 kg</p> <p>Maximum 47 600 kg</p> <p>Maximum 50 600 kg</p> <p>Maximum 52 100 kg</p>	<p>Maximum 38 200 kg</p> <p>Maximum 38 700 kg</p> <p>Maximum 42 000 kg</p> <p>Maximum 43 000 kg</p> <p>Maximum 46 000 kg</p> <p>Maximum 47 500 kg</p>
<p>8) <u>Maximum Gross Vehicle Weights Truck axle group spread 3.0 m to <3.1 m</u></p> <p>(a) pony trailer with single axle</p> <p>(i) Wheelbase 6.25 m to 7.50 m</p> <p>(ii) Wheelbase >7.50 m</p> <p>(b) pony trailer with a tandem axle group</p> <p>(i) Wheelbase 6.25 m to 7.50 m</p> <p>(ii) Wheelbase >7.50 m</p> <p>(c) pony trailer with a tridem axle group</p> <p>(i) Wheelbase 6.25 m to 7.50 m</p> <p>(ii) Wheelbase >7.50 m</p>	<p>Maximum 43 800 kg</p> <p>Maximum 44 300 kg</p> <p>Maximum 47 600 kg</p> <p>Maximum 48 600 kg</p> <p>Maximum 51 600 kg</p> <p>Maximum 53 100 kg</p>	<p>Maximum 38 200 kg</p> <p>Maximum 38 700 kg</p> <p>Maximum 42 000 kg</p> <p>Maximum 43 000 kg</p> <p>Maximum 46 000 kg</p> <p>Maximum 47 500 kg</p>

Configuration 15: Tandem Steer Tridem Drive Straight Truck - Pony Trailer Combination (continued)		
WEIGHT LIMITS - Winter Weight Season		
	Primary and Secondary Highways	Municipal Highways
1) <u>Tandem Steering Axle Group</u>	Minimum 40% of drive axles at all times to a maximum 13 600 kg	Minimum 40% of drive axles at all times to a maximum 11 000 kg
2) <u>Tridem Drive Axle Group</u>		
(a) Axle Spread 2.4 m to <2.7 m	Maximum 21 000 kg	Maximum 21 000 kg
(b) Axle Spread 2.7 m to <3.0 m	Maximum 22 000 kg	Maximum 21 000 kg
(c) Axle Spread 3.0 m to 3.1 m	Maximum 23 000 kg	Maximum 23 000 kg
3) <u>Pony Trailer with a single axle</u>		
(a) Wheelbase 6.25 m to 7.50 m	Maximum 7 200 kg	Maximum 7 200 kg
(b) Wheelbase >7.50 m	Maximum 7 700 kg	Maximum 7 700 kg
4) <u>Pony Trailer with a tandem axle group</u>		
(a) Wheelbase 6.25 m to 7.50 m	Maximum 11 000 kg	Maximum 11 000 kg
(b) Wheelbase >7.50 m	Maximum 12 000 kg	Maximum 12 000 kg
5) <u>Pony Trailer with a tridem axle group</u>		
(a) Wheelbase 6.25 m to 7.50 m	Maximum 15 000 kg	Maximum 15 000 kg
(b) Wheelbase >7.50 m	Maximum 16 500 kg	Maximum 16 500 kg
6) <u>Maximum Gross Vehicle Weights Truck axle group spread 2.4 m to <2.7 m</u>		
(a) pony trailer with single axle		
(i) Wheelbase 6.25 m to 7.50 m	Maximum 41 800 kg	Maximum 39 200 kg
(ii) Wheelbase >7.50 m	Maximum 42 300 kg	Maximum 39 700 kg
(b) pony trailer with a tandem axle group		
(i) Wheelbase 6.25 m to 7.50 m	Maximum 45 600 kg	Maximum 43 000 kg
(ii) Wheelbase >7.50 m	Maximum 46 600 kg	Maximum 44 000 kg
(c) pony trailer with a tridem axle group		
(i) Wheelbase 6.25 m to 7.50 m	Maximum 49 600 kg	Maximum 47 000 kg
(ii) Wheelbase >7.50 m	Maximum 51 100 kg	Maximum 48 500 kg

<i>WEIGHT LIMITS - Winter Weight Season</i> (continued)		
<p>7) <u>Maximum Gross Vehicle Weights Truck axle group spread 2.4 m to <3.0 m</u></p> <p>(a) pony trailer with single axle</p> <p>(i) Wheelbase 6.25 m to 7.50 m</p> <p>(ii) Wheelbase >7.50 m</p> <p>(b) pony trailer with a tandem axle group</p> <p>(i) Wheelbase 6.25 m to 7.50 m</p> <p>(ii) Wheelbase >7.50 m</p> <p>(c) pony trailer with a tridem axle group</p> <p>(i) Wheelbase 6.25 m to 7.50 m</p> <p>(ii) Wheelbase >7.50 m</p>	<p>Maximum 42 800 kg</p> <p>Maximum 43 300 kg</p> <p>Maximum 46 600 kg</p> <p>Maximum 47 600 kg</p> <p>Maximum 50 600 kg</p> <p>Maximum 52 100 kg</p>	<p>Maximum 39 200 kg</p> <p>Maximum 39 700 kg</p> <p>Maximum 43 000 kg</p> <p>Maximum 44 000 kg</p> <p>Maximum 47 000 kg</p> <p>Maximum 48 500 kg</p>
<p>8) <u>Maximum Gross Vehicle Weights Truck axle group spread 3.0 m to <3.1 m</u></p> <p>(a) pony trailer with single axle</p> <p>(i) Wheelbase 6.25 m to 7.50 m</p> <p>(ii) Wheelbase >7.50 m</p> <p>(b) pony trailer with a tandem axle group</p> <p>(i) Wheelbase 6.25 m to 7.50 m</p> <p>(ii) Wheelbase >7.50 m</p> <p>(c) pony trailer with a tridem axle group</p> <p>(i) Wheelbase 6.25 m to 7.50 m</p> <p>(ii) Wheelbase >7.50 m</p>	<p>Maximum 43 800 kg</p> <p>Maximum 44 300 kg</p> <p>Maximum 47 600 kg</p> <p>Maximum 48 600 kg</p> <p>Maximum 51 600 kg</p> <p>Maximum 53 100 kg</p>	<p>Maximum 41 200 kg</p> <p>Maximum 41 700 kg</p> <p>Maximum 45 000 kg</p> <p>Maximum 46 000 kg</p> <p>Maximum 49 000 kg</p> <p>Maximum 50 500 kg</p>

Configuration 16: Tridem Drive Truck Tractor-Semi-trailer Combination
The information contained in this schedule applies to all truck tractors equipped with a tridem drive axle group in combination with a semi-trailer.
Part 1 - Dimension Limits

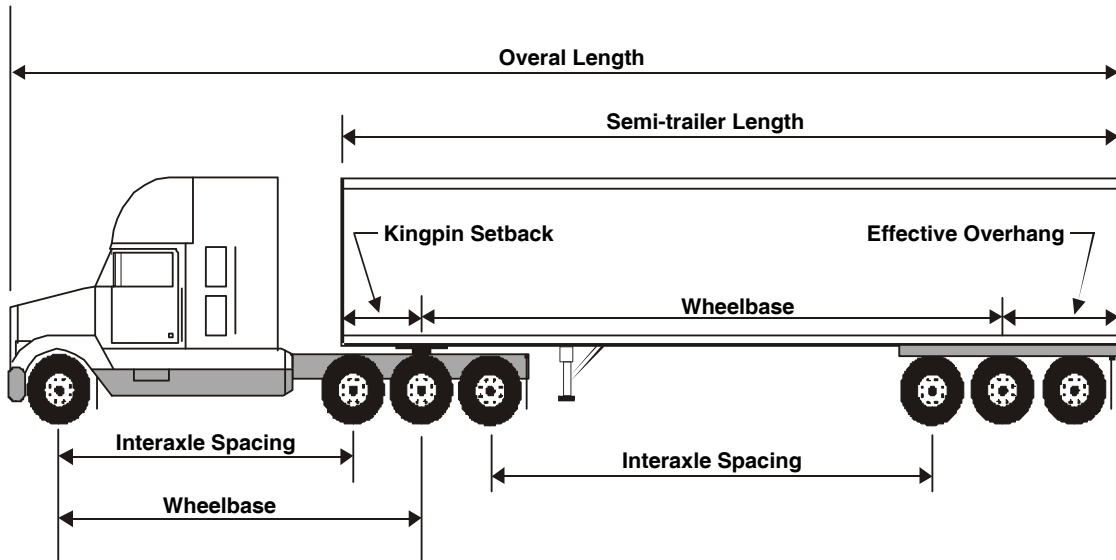

DIMENSION	LIMIT
Overall Length	Maximum 23.5 m
Overall Width	Maximum 2.6 m
Overall Height	Maximum 4.15 m
Box Length	Maximum 16.2 m
Truck Tractor:	
Wheelbase	Minimum 6.6 m/Maximum 6.8 m
Tridem Drive Axle Group Spread (Note 1)	Minimum 2.4 m/Maximum 2.8 m
Tridem Drive Axle Group Track Width	Minimum 2.5 m/Maximum 2.6 m

Configuration 16: Tridem Drive Truck Tractor-Semi-trailer Combination (continued)	
DIMENSION	LIMIT
Semitrailer	
Length	Maximum 16.2 m
Wheelbase Single, Tandem or Tridem Axle Group	Minimum 6.25 m/Maximum 12.5 m
Kingpin Setback	Maximum 2.0 m radius
Effective Overhang	Maximum 35% of wheelbase
Tandem Axle Group Spread	Minimum 1.0 m/Maximum 3.4 m
Tridem Axle Group Spread	Minimum 2.4 m/Maximum 3.7 m
Track Width	Minimum 2.5 m/Maximum 2.6 m

Interaxle Spacings	
Tridem Axle Group to Single Axle	Minimum 3.0 m
Tridem Axle Group to Tandem Axle Group	Minimum 5.5 m
Tridem Axle Group to Tridem Axle Group	Minimum 6.0 m

Note 1: All three axles in tridem group must drive (no pusher, tag or lift axles allowed). Drive axle locking devices must be unlocked while operating on a highway.

Configuration 16: Tridem Drive Truck Tractor-Semi-trailer Combination
The information contained in this schedule applies to all truck tractors equipped with a tridem drive axle group in combination with a semi-trailer.
Part 2 - Weight Limits

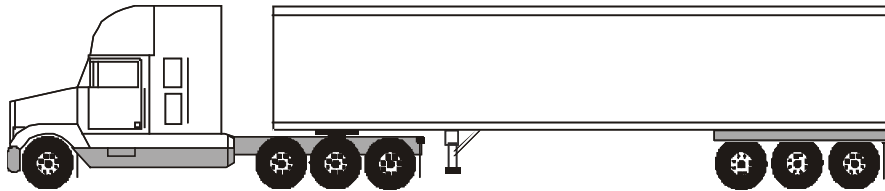

WEIGHT LIMITS		
	Primary Highway	Secondary and Municipal Highways
Truck Tractor:		
1) <u>Steering Axle</u>	Minimum 27% of drive axles at all times to a maximum 7 300 kg	Minimum 27% of drive axles at all times to a maximum 7 300 kg
2) <u>Tridem Drive Axle Group</u>		
(a) Axle Spread 2.4 m to <2.7 m	Maximum 21 000 kg	Maximum 20 000 kg
(b) Axle Spread 2.7 m to 2.8 m	Maximum 22 000 kg	Maximum 20 000 kg
3) <u>Semi-Trailer Axle Group</u>		
(a) Single Axle	Maximum 9 100 kg	Maximum 8 200 kg
(b) Tandem Axle Group	Maximum 17 000 kg	Maximum 14 500 kg
(c) Tridem Axle Group		
(i) Tridem Spread 2.4 m to 3.0 m	Maximum 21 000 kg	Maximum 20 000 kg
(ii) Tridem Spread >3.0 m to 3.6 m	Maximum 23 000 kg	Maximum 20 000 kg
(iii) Tridem Spread >3.0 m to 3.6 m on Highways listed in Appendix E (Note 1)	Maximum 24 000 kg	Maximum 20 000 kg
(iv) Tridem Spread >3.6 m to 3.7 m	Maximum 24 000 kg	

<p>4) A Truck Tractor with an axle spread of 2.4 m to <2.7 m combined with a semi-trailer with a:</p> <p>(a) Single axle</p> <p>(b) Tandem axle group</p> <p>(c) Tridem axle group</p> <p>(i) Axle Spread 2.4 m to 3.0 m</p> <p>(ii) Axle Spread >3.0 m to 3.6 m</p> <p>(iii) Tridem Spread >3.0 m to 3.6 m on Highways listed in Appendix E (Note 2)</p> <p>(iv) Axle Spread >3.6 m to 3.7 m</p>	<p>Maximum 37 400 kg</p> <p>Maximum 45 300 kg</p> <p>Maximum 49 300 kg</p> <p>Maximum 51 300 kg</p> <p>Maximum 52 300 kg</p> <p>Maximum 52 300 kg</p>	<p>Maximum 35 500 kg</p> <p>Maximum 41 800 kg</p> <p>Maximum 47 300 kg</p> <p>Maximum 47 300 kg</p> <p>Maximum 47 300 kg</p> <p>Maximum 47 300 kg</p>
<p>5) A Truck Tractor with an axle spread of 2.7 m to 2.8 m combined with a semi-trailer with a:</p> <p>(a) Single axle</p> <p>(b) Tandem axle group</p> <p>(c) Tridem axle group</p> <p>(i) Axle Spread 2.4 m to 3.0 m</p> <p>(ii) Axle Spread >3.0 m to 3.6 m</p> <p>(iii) Tridem Spread >3.0 m to 3.6 m on Highways listed in Appendix E (Note 3)</p> <p>(iv) Axle Spread >3.6 m to 3.7 m</p>	<p>Maximum 38 400 kg</p> <p>Maximum 46 300 kg</p> <p>Maximum 50 300 kg</p> <p>Maximum 52 300 kg</p> <p>Maximum 53 300 kg</p> <p>Maximum 53 300 kg</p>	<p>Maximum 35 500 kg</p> <p>Maximum 41 800 kg</p> <p>Maximum 47 300 kg</p> <p>Maximum 47 300 kg</p> <p>Maximum 47 300 kg</p> <p>Maximum 47 300 kg</p>

Note 1: The maximum allowable weight on a tridem axle group on a semi-trailer with a spread greater than 3.0 m up to 3.6 m is 24 000 kg on provincial highways or portions of provincial highways listed in Appendix E.

Note 2: The maximum allowable weight on a tridem drive truck tractor semi-trailer combination is 52 300 kg on provincial highways or portions of provincial highways listed in Appendix E.

Note 3: The maximum allowable weight on a tridem drive truck tractor semi-trailer combination is 53 300 kg on provincial highways or portions of provincial highways listed in Appendix E.

Configuration 16: Tridem Drive Truck Tractor-Semi-Trailer Combination (continued)		
<i>WEIGHT LIMITS - Winter Weight Season</i>		
Truck Tractor:	Primary Highway	Secondary and Municipal Highways
1) <u>Steering Axle</u>	Minimum 27% of drive axles at all times to a maximum 7 300 kg	Minimum 27% of drive axles at all times to a maximum 7 300 kg
2) <u>Tridem Drive Axle Group</u>		
(a) Axle Spread 2.4 m to <2.7 m	Maximum 21 000 kg	Maximum 21 000 kg
(b) Axle Spread 2.7 m to 2.8 m	Maximum 22 000 kg	Maximum 21 000 kg
3) <u>Semi-Trailer Axle Group</u>		
(a) Single Axle	Maximum 10 000 kg	Maximum 10 000 kg
(b) Tandem Axle Group	Maximum 18 000 kg	Maximum 18 000 kg
(c) Tridem Axle Group		
(i) Tridem Spread 2.4 m to 3.0 m	Maximum 21 000 kg	Maximum 21 000 kg
(ii) Tridem Spread >3.0 m to 3.6 m	Maximum 23 000 kg	Maximum 23 000 kg
(iii) Tridem Spread >3.0 m to 3.6 m on Highways listed in Appendix E (Note 1)	Maximum 24 000 kg	
(iv) Tridem Spread >3.6 m to 3.7 m	Maximum 24 000 kg	Maximum 24 000 kg
4) <u>A Truck Tractor with an axle spread of 2.4 m to <2.7 m combined with a semi-trailer with a:</u>		
(a) Single axle	Maximum 38 300 kg	Maximum 38 300 kg
(b) Tandem axle group	Maximum 46 300 kg	Maximum 46 300 kg
(c) Tridem axle group		
(i) Axle Spread 2.4 m to 3.0 m	Maximum 49 300 kg	Maximum 49 300 kg
(ii) Axle Spread >3.0 m to 3.6 m	Maximum 51 300 kg	Maximum 51 300 kg
(iii) Tridem Spread >3.0 m to 3.6 m on Highways listed in Appendix E (Note 2)	Maximum 52 300 kg	
(iv) Axle Spread >3.6 m to 3.7 m	Maximum 52 300 kg	Maximum 52 300 kg

5) <u>A Truck Tractor with an axle spread of 2.7 m to 2.8 m combined with a semi-trailer with a:</u>		
(a) Single axle	Maximum 39 300 kg	Maximum 38 300 kg
(b) Tandem axle group	Maximum 47 300 kg	Maximum 46 300 kg
(c) Tridem axle group		
(i) Axle Spread 2.4 m to 3.0 m	Maximum 50 300 kg	Maximum 49 300 kg
(ii) Axle Spread >3.0 m to 3.6 m	Maximum 52 300 kg	Maximum 51 300 kg
(iii) Tridem Spread >3.0 m to 3.6 m on Highways listed in Appendix E (Note 3)	Maximum 53 300 kg	
(iv) Axle Spread >3.6 m to 3.7 m	Maximum 53 300 kg	Maximum 52 300 kg

Note 1: The maximum allowable weight on a tridem axle group on a semi-trailer with a spread greater than 3.0 m up to 3.6 m is 24 000 kg on provincial highways or portions of provincial highways listed in Appendix E.

Note 2: The maximum allowable weight on a tridem drive truck tractor semi-trailer combination is 52 300 kg on provincial highways or portions of provincial highways listed in Appendix E.

Note 3: The maximum allowable weight on a tridem drive truck tractor semi-trailer combination is 53 300 kg on provincial highways or portions of provincial highways listed in Appendix E.

Configuration 17: Tridem Drive Truck Tractor B-Train Combination

The information contained in this schedule applies to all truck tractors equipped with a tridem drive axle group in combination with a semi trailer towing another semi trailer attached to a fifth wheel mounted on the rear of the first semi trailer.

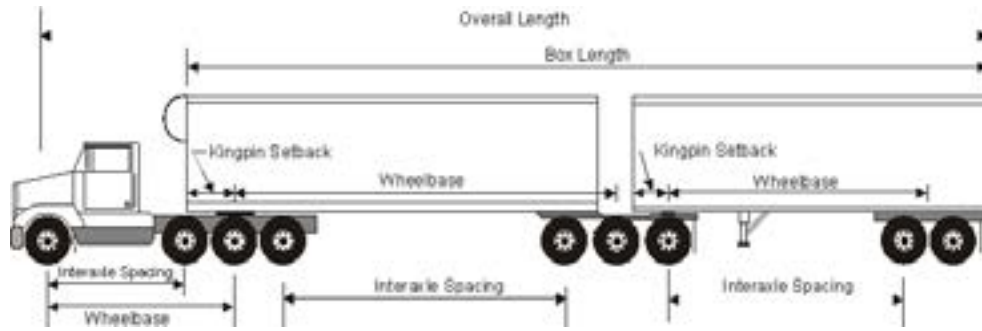
Part 1 - Dimension Limits

DIMENSION	LIMIT
Overall Length (Note 1)	Maximum 27.5 m
Overall Width	Maximum 2.6 m
Overall Height	Maximum 4.15 m
Box Length	Maximum 20.0 m
Tractor:	
Wheelbase	Minimum 6.6 m/Maximum 6.8 m
Tandem Axle Group Spread	Minimum 1.0 m/Maximum 1.85 m
Tridem Drive Axle Group Spread (Note 1)	Minimum 2.4 m/Maximum 2.8 m
Tridem Drive Axle Group Track Width	Minimum 2.5 m/Maximum 2.6 m
Lead Semi-trailer	
Wheelbase	Minimum 6.25 m
Kingpin Setback	Maximum 2.0 m radius
Tandem Axle Group Spread	Minimum 1.0 m/Maximum 3.4 m
Tridem Axle Group Spread	Minimum 2.4 m/Maximum 3.1 m
Track Width	Minimum 2.5 m/Maximum 2.6 m
Fifth Wheel Position	No more than 0.3 m behind the centre of the rearmost axle on the semi-trailer

Note 1: The overall length is inclusive of the heavy duty bumper or device designed to reduce the impact of wildlife collisions that is mounted on the front of the truck tractor.

Configuration 17: Tridem Drive Truck Tractor B-Train Combination (continued)	
DIMENSION	LIMIT
Second Semi-trailer	
Wheelbase	Minimum 6.25 m
Kingpin Setback	Maximum 2.0 m radius
Tandem Axle Group Spread	Minimum 1.0 m/Maximum 3.4 m
Tridem Axle Group Spread	Minimum 2.4 m/Maximum 3.1 m
Track Width	Minimum 2.5 m/Maximum 2.6 m
Sum of Semi-trailer Wheelbases (Note 2)	
	Maximum 17.0 m
Interaxle Spacings	
Single Axle to Single, Tandem or Tridem Axle Group	Minimum 3.0 m
Tandem Axle Group to Tandem Axle Group	Minimum 5.0 m
Tandem Axle Group to Tridem Axle Group	Minimum 5.5 m
Tridem Axle Group to Tridem Axle Group	Minimum 6.0 m

Note 1: All three axles in tridem group must drive (no pusher, tag or lift axles allowed). Drive axle locking devices must be unlocked while operating on a highway.

Note 2: The sum of semi-trailer wheelbases limit only applies if both semi-trailers were manufactured after December 31, 1991.

Configuration 17: Tridem Drive Truck Tractor B-Train Combination

The information contained in this schedule applies to all truck tractors equipped with a tridem drive axle group in combination with a semi-trailer towing another semi-trailer attached to a fifth wheel mounted on the rear of the first semi-trailer.

Part 2 - Weight Limits

WEIGHT LIMITS		
	Primary Highway	Secondary and Municipal Highways
1) Steering Axle	Minimum 27% of drive axles at all times to a maximum 7 300 kg	Minimum 27% of drive axles at all times to a maximum 7 300 kg
2) Tridem Drive Axle Group		
(a) Axle Spread 2.4 m to <2.7 m	Maximum 21 000 kg	Maximum 20 000 kg
(b) Axle Spread 2.7 m to 2.8 m	Maximum 22 000 kg	Maximum 20 000 kg
3) Semi-Trailer Axle Group		
(a) Single Axle	Maximum 9 100 kg	Maximum 8 200 kg
(b) Tandem Axle Group	Maximum 17 000 kg	Maximum 14 500 kg
(c) Tridem Axle Group		
(i) Tridem Spread 2.4 m to <3.0 m	Maximum 21 000 kg	Maximum 20 000 kg
(ii) Tridem Spread 3.0 m to 3.1 m (Note 1)	Maximum 23 000 kg	Maximum 20 000 kg
(iii) Tridem Spread >3.0 m to 3.1 m on highways listed in Appendix E (Note 2)	Maximum 24 000 kg	

Note 1: The maximum spread on a tridem axle group on a semi-trailer for in a B-train combination is 3.1 m

Note 2: The maximum allowable weight on a tridem axle group on a B-train is 24 000 kg on provincial highways or portions of provincial highways listed in Appendix E.

Configuration 17: Tridem Drive Truck Tractor B-Train Combination (continued)			
WEIGHT LIMITS - Primary Highways			
	Lead Semi-trailer	Second Semi-trailer	Maximum Gross Vehicle Weight
A truck tractor with an axle spread of 2.4 m to <2.7 m	Tandem axle group	Single axle	54 400 kg
	Tandem axle group	Tandem axle group	62 300 kg
	Tandem axle group	Tridem Axle Group, Spread 2.4 m to 3.1 m	62 500 kg
	Tandem axle group	Tridem Axle Group, Spread 3.0 m to 3.1 m on highways listed in Appendix E lead trailer only (Note 1)	63 500 kg
	Tridem Axle Group, Spread 2.4 m to <3.0 m	Single axle	58 400 kg
	Tridem Axle Group Spread 3.0 m to 3.1 m	Single axle	60 400 kg
	Tridem Axle Group, Spread 3.0 m to 3.1 m on highways listed in Appendix E lead trailer only (Note 1)	Single axle	61 400 kg
	Tridem Axle Group, Spread 2.4 m to <3.0 m	Tridem Axle Group, Spread 3.0 m to 3.1 m on highways listed in Appendix E lead trailer only (Note 1)	63 500 kg
	Tridem Axle Group, Spread 2.4 m to 3.1 m	Tandem axle group	62 500 kg
	Tridem Axle Group, Spread 2.4 m to 3.1 m	Tridem Axle Group, Spread 2.4 m to 3.1 m	62 500 kg
	Tridem Axle Group, Spread 3.0 m to 3.1 m on highways listed in Appendix E lead trailer only (Note 1)	Tridem Axle Group, Spread 3.0 m to 3.1 m on highways listed in Appendix E lead trailer only (Note 1)	63 500 kg

A truck tractor with an axle spread of 2.7 m to 2.8 m	Tandem axle group	Single axle	55 400 kg
	Tandem axle group	Tandem axle group	62 500 kg
	Tandem axle group	Tridem Axle Group, Spread 2.4 m to 3.1 m	62 500 kg
	Tandem axle group	Tridem Axle Group, Spread 3.0 m to 3.1 m on highways listed in Appendix E lead trailer only (Note 1)	63 500 kg
	Tridem Axle Group, Spread 2.4 m to <3.0 m	Single axle	59 400 kg
	Tridem Axle Group Spread 3.0 m to 3.1 m	Single axle	61 400 kg
	Tridem Axle Group, Spread 3.0 m to 3.1 m on highways listed in Appendix E lead trailer only (Note 1)	Single axle	62 400 kg
	Tridem Axle Group, Spread 2.4 m to 3.1 m	Tandem axle group	62 500 kg
	Tridem Axle Group, Spread 2.4 m to <3.0 m	Tridem Axle Group, Spread 3.0 m to 3.1 m on highways listed in Appendix E lead trailer only (Note 1)	63 500 kg
	Tridem Axle Group, Spread 2.4 m to 3.1 m	Tridem Axle Group, Spread 2.4 m to 3.1 m	62 500 kg
	Tridem Axle Group, Spread 3.0 m to 3.1 m on highways listed in Appendix E lead trailer only (Note 1)	Tridem Axle Group, Spread 3.0 m to 3.1 m on highways listed in Appendix E lead trailer only (Note 1)	63 500 kg

Note 1: The maximum allowable weight on a B-train is 63 500 kg on provincial highways or portions of provincial highways listed in Appendix E.

Configuration 17: Tridem Drive Truck Tractor B-Train Combination (continued)			
WEIGHT LIMITS - Secondary and Municipal Highways			
	Lead Semi-trailer	Second Semi-trailer	Maximum Gross Vehicle
A truck tractor with an axle spread of 2.4 m to <2.7 m	Tandem axle group	Single axle	50 000 kg
	Tandem axle group	Tandem axle group	56 300 kg
	Tandem axle group	Tridem Axle Group, Spread 2.4 m to 3.1 m	61 800 kg
	Tridem Axle Group, Spread 2.4 m to 3.1 m	Single axle	55 500 kg
	Tridem Axle Group, Spread 2.4 m to 3.1 m	Tandem axle group	61 800 kg
	Tridem Axle Group, Spread 2.4 m to 3.1 m	Tridem Axle Group, Spread 2.4 m to 3.1 m	61 800 kg
A truck tractor with an axle spread of 2.7 m to 2.8 m	Tandem axle group	Single axle	50 000 kg
	Tandem axle group	Tandem axle group	56 300 kg
	Tandem axle group	Tridem Axle Group, Spread 2.4 m to 3.1 m	61 800 kg
	Tridem Axle Group, Spread 2.4 m to 3.1 m	Single axle	55 500 kg
	Tridem Axle Group, Spread 2.4 m to 3.1 m	Tandem axle group	61 800 kg
	Tridem Axle Group, Spread 2.4 m to 3.1 m	Tridem Axle Group, Spread 2.4 m to 3.1 m	61 800 kg

Configuration 17: Tridem Drive Truck Tractor B-Train Combination (continued)		
<i>WEIGHT LIMITS - Winter Weight Season</i>		
	Primary and Secondary Highway	Municipal Highways
1) Steering Axle	Maximum 7 300 kg	Maximum 7 300 kg
2) Tridem Drive Axle Group		
(a) Axle Spread 2.4 m to <2.7 m	Maximum 21 000 kg	Maximum 21 000 kg
(b) Axle Spread 2.7 m to 2.8 m	Maximum 22 000 kg	Maximum 21 000 kg
3) Semi-Trailer Axle Group(s)		
(a) Single Axle	Maximum 10 000 kg	Maximum 10 000 kg
(b) Tandem Axle Group	Maximum 18 000 kg	Maximum 18 000 kg
(c) Tridem Axle Group		
(i) Tridem Spread 2.4 m to <3.0 m	Maximum 21 000 kg	Maximum 21 000 kg
(ii) Tridem Spread 3.0 m to 3.1 m	Maximum 23 000 kg	Maximum 23 000 kg
(iii) Tridem Spread 3.0 m to 3.1 m on highways listed in Appendix E (Note 1)	Maximum 24 000 kg	

Note 1: The maximum allowable weight on a tridem axle group on a B-train is 24 000 kg on provincial highways or portions of provincial highways listed in Appendix E.

Configuration 17: Tridem Drive Truck Tractor B-Train Combination (continued)			
GROSS VEHICLE WEIGHT LIMITS - Winter Weight Season - Primary and Secondary Highways			
	Lead Semi-trailer	Second Semi-trailer	Maximum Gross Vehicle Weight
A truck tractor with an axle spread of 2.4 m to <2.7 m	Tandem axle group	Single axle	56 300 kg
	Tandem axle group	Tandem axle group	62 500 kg
	Tandem axle group	Tridem Axle Group, Spread 2.4 m to 3.1 m	62 500 kg
	Tandem axle group	Tridem Axle Group, Spread 3.0 m to 3.1 m on highways listed in Appendix E lead trailer only (Note 1)	63 500 kg
	Tridem Axle Group, Spread 2.4 m to <3.0 m	Single axle	59 300 kg
	Tridem Axle Group, Spread 3.0 m to 3.1 m	Single axle	61 300 kg
	Tridem Axle Group, Spread 3.0 m to 3.1 m on highways listed in Appendix E lead trailer only (Note 1)	Single axle	62 300 kg
	Tridem Axle Group, Spread 2.4 m to 3.1 m	Tandem axle group	62 500 kg
	Tridem Axle Group, Spread 2.4 m <3.0 m	Tridem Axle Group, Spread 3.0 m to 3.1 m on highways listed in Appendix E lead trailer only (Note 1)	63 500 kg
	Tridem Axle Group, Spread 2.4 m to 3.1 m	Tridem Axle Group, Spread 2.4 m to 3.1 m	62 500 kg

	Tridem Axle Group, Spread 3.0 m to 3.1 m on highways listed in Appendix E lead trailer only (Note 1)	Tridem Axle Group, Spread 3.0 m to 3.1 m on highways listed in Appendix E lead trailer only (Note 1)	63 500 kg
A truck tractor with an axle spread of 2.7 m to 2.8 m	Tandem axle group	Single axle	57 300 kg
	Tandem axle group	Tandem axle group	62 500 kg
	Tandem axle group	Tridem Axle Group, Spread 2.4 m to 3.1 m	63 500 kg
	Tandem axle group	Tridem Axle Group, Spread 3.0 m to 3.1 m on highways listed in Appendix E lead trailer only (Note 1)	63 500 kg
	Tridem Axle Group, Spread 2.4 m to <3.0 m	Single axle	60 300 kg
	Tridem Axle Group, Spread 3.0 m to 3.1 m	Single axle	62 300 kg
	Tridem Axle Group, Spread 2.4 m to 3.1 m on highways listed in Appendix E lead trailer only (Note 1)	Single axle	63 300 kg
	Tridem Axle Group, Spread 2.4 m to 3.1 m	Tandem axle group	62 500 kg
	Tridem Axle Group, Spread 2.4 m to 3.1 m	Tridem Axle Group, Spread 2.4 m to 3.1 m	62 500 kg
	Tridem Axle Group, Spread 3.0 m to 3.1 m on highways listed in Appendix E lead trailer only (Note 1)	Tridem Axle Group, Spread 3.0 m to 3.1 m on highways listed in Appendix E lead trailer only (Note 1)	63 500 kg

Note 1: The maximum allowable weight on a B-train is 63 500 kg on provincial highways or portions of provincial highways listed in Appendix E.

Configuration 17: Tridem Drive Truck Tractor B-Train Combination (continued)			
GROSS VEHICLE WEIGHT LIMITS - Winter Weight Season - Municipal Highways			
	Lead Semi-trailer	Second Semi-trailer	Maximum Gross Vehicle Weight
A truck with an axle spread of 2.4 m to <2.7 m	Tandem axle group	Single axle	56 300 kg
	Tandem axle group	Tandem axle group	61 800 kg
	Tandem axle group	Tridem Axle Group, Spread 2.4 m to 3.1 m	61 800 kg
	Tridem Axle Group, Spread 2.4 m to <3.0 m	Single Axle	59 300 kg
	Tridem Axle Group, Spread 3.0 m to 3.1 m	Single axle	61 300 kg
	Tridem Axle Group, Spread 2.4 m to 3.1 m	Tandem axle group	61 800 kg
	Tridem Axle Group, Spread 2.4 m to 3.1 m	Tridem Axle Group, Spread 2.4 m to 3.1 m	61 800 kg
A truck tractor with an axle spread of 2.7 m to 2.8 m	Tandem axle group	Single axle	56 300 kg
	Tandem axle group	Tandem axle group	61 800 kg
	Tandem axle group	Tridem Axle Group, Spread 2.4 m to 3.1 m	61 800 kg
	Tridem Axle Group, Spread 2.4 m to <3.0 m	Single axle	59 300 kg
	Tridem Axle Group, Spread 3.0 m to 3.1 m	Single axle	61 500 kg
	Tridem Axle Group, Spread 2.4 m to 3.1 m	Tandem axle group	61 800 kg
	Tridem Axle Group, Spread 2.4 m to 3.1 m	Tridem Axle Group, Spread 2.4 m to 3.1 m	61 800 kg

Configuration 18: Tridem Drive Truck Tractor B Train Combination

Repealed. 25 Sep 2020 SR 106/2020 s4.

Configuration 19: Auto-carrier
An auto-carrier is a unit designed and used to transport automobiles, vans, small trucks and boats.
Part 1 - Dimension Limits

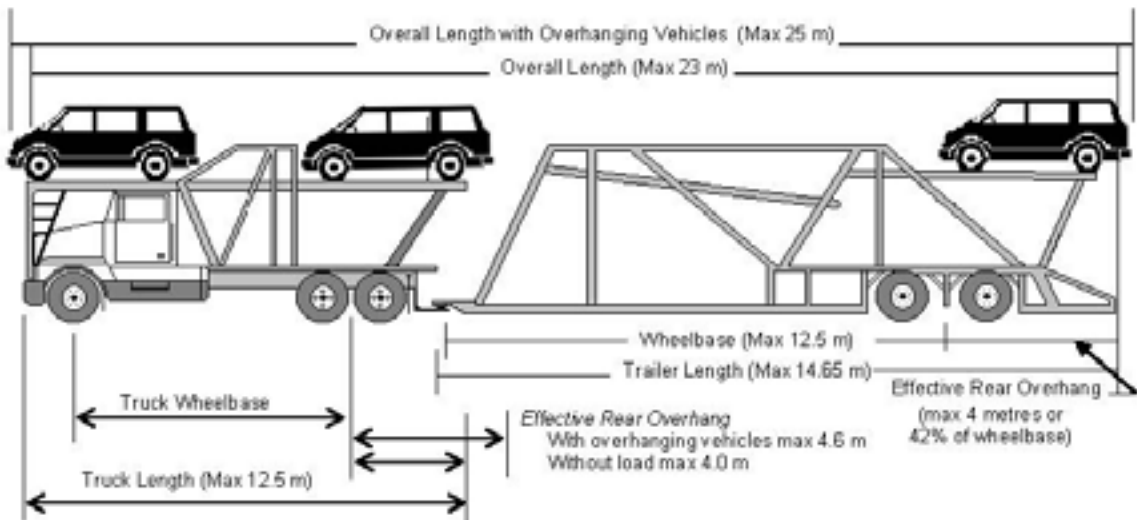

DIMENSION	LIMIT
Overall Length	
Unloaded	Maximum 23 m
Loaded	Maximum 25 m
Overall Width	Maximum 2.6 m
Overall Height	
Unloaded	Maximum 4.15 m
Loaded	Maximum 4.3 m
Truck Tractor:	
Length	Maximum 12.5 m
Wheelbase	Maximum 6.2 m
Tandem Axle Group Spread	Minimum 1.2 m/Maximum 1.85 m
Load overhang at front of tractor (beyond tractor bumper)	Maximum 1 m
Effective rear overhang	
Unloaded	Maximum 4 m
Loaded	Maximum 4.6 m

Semi-trailer	
Length (Note 1)	
Unloaded	Maximum 16.2 m
Loaded	Maximum 18.0 m
Wheelbase	Minimum 6.25 m/Maximum 12.5m
Effective rear overhang	Maximum 4 m or 42% of wheelbase, whichever is greater
Load overhang at rear of semi-trailer	Maximum 1.2 m
Tandem Axle Group Spread	Minimum 1.2 m/Maximum 3.4 m
Tridem Axle Group Spread	Minimum 2.4 m/Maximum 3.7 m
Interaxle Spacing	
Single axle to Single or Tandem axle	Minimum 3 m
Tandem axle to Tandem axle	Minimum 5 m
Tandem axle to Tridem axle	Minimum 5.5 m

Note 1: The maximum trailer length for a stinger steer auto-carrier is 14.65 m.

Configuration 19: Auto-carrier

An auto-carrier is a unit designed and used to transport automobiles, vans, small trucks and boats.

Part 2 - Weight Limits

WEIGHT LIMITS		
	Primary Highway	Secondary and Municipal Highways
1) Steering Axle	Maximum 6 000 kg	Maximum 6 000 kg
2) Drive Axle Group		
(a) Single Axle	Maximum 9 100 kg	Maximum 8 200 kg
(b) Tandem Axle Group	Maximum 17 000 kg	Maximum 14 500 kg
3) Axle Group		
(a) Single Axle	Maximum 9 100 kg	Maximum 8 200 kg
(b) Tandem Axle Group	Maximum 17 000 kg	Maximum 14 500 kg
(c) Tridem Axle Group		
(i) Tridem Spread 2.4 m to 3.0 m	Maximum 21 000 kg	Maximum 20 000 kg
(ii) Tridem Spread >3.0 m to 3.6 m	Maximum 23 000 kg	Maximum 20 000 kg
(iii) Tridem Spread >3.0 m to 3.6 m on highways listed in Appendix E (Note 1)	Maximum 24 000 kg	
(iv) Tridem Spread >3.6 m to 3.7 m	Maximum 24 000 kg	Maximum 20 000 kg

4) Maximum Gross Vehicle Weights		
(a) Two axle truck tractor, single axle trailer	Maximum 24 200 kg	Maximum 22 400 kg
(b) Two axle truck tractor, tandem axle trailer	Maximum 32 100 kg	Maximum 28 700 kg
(c) Three axle truck tractor, single axle trailer	Maximum 32 100 kg	Maximum 28 700 kg
(d) Three axle truck tractor, tandem axle trailer	Maximum 40 000 kg	Maximum 35 000 kg
(e) Three axle truck tractor, tridem axle trailer	Maximum 44 000 kg	Maximum 40 500 kg
(i) Tridem Spread 2.4 m to 3.0 m	Maximum 46 000 kg	Maximum 40 500 kg
(ii) Tridem Spread >3.0 m to 3.6 m	Maximum 47 000 kg	
(iii) Tridem Spread >3.0 m to 3.6 m on Highways listed in Appendix E (Note 1)	Maximum 47 000 kg	Maximum 40 500 kg
(iv) Tridem Spread >3.6 m to 3.7 m		

Note 1: The maximum allowable weight on a tridem axle group on a semi-trailer with a spread greater than 3.0 m up to 3.6 m is 24 000 kg on provincial highways or portions of provincial highways listed in Appendix E.

Configuration 19: Auto-carrier (continued)		
<i>WEIGHT LIMITS – Winter Weight Season</i>		
	Primary Highway	Secondary and Municipal Highways
1) Steering Axle	Maximum 6 000 kg	Maximum 6 000 kg
2) Drive Axle Group		
(a) Single Axle	Maximum 10 000 kg	Maximum 10 000 kg
(b) Tandem Axle Group	Maximum 18 000 kg	Maximum 18 000 kg
3) Axle Group		
(a) Single Axle	Maximum 10 000 kg	Maximum 10 000 kg
(b) Tandem Axle Group	Maximum 18 000 kg	Maximum 18 000 kg
(c) Tridem Axle Group		
(i) Tridem Spread 2.4 m to 3.0 m	Maximum 21 000 kg	Maximum 21 000 kg
(ii) Tridem Spread >3.0 m to 3.6 m	Maximum 23 000 kg	Maximum 23 000 kg
(iii) Tridem Spread >3.0 m to 3.6 m on highways listed in Appendix E (Note 1)	Maximum 24 000 kg	
(iv) Tridem Spread >3.6 m to 3.7 m	Maximum 24 000 kg	Maximum 24 000 kg

H-3.01 REG 8 VEHICLE WEIGHT AND DIMENSION, 2010

4) Maximum Gross Vehicle Weights		
(a) Two axle truck tractor, single axle trailer	Maximum 26 000 kg	Maximum 26 000 kg
(b) Two axle truck tractor, tandem axle trailer	Maximum 34 000 kg	Maximum 34 000 kg
(c) Three axle truck tractor, single axle trailer	Maximum 34 000 kg	Maximum 34 000 kg
(d) Three axle truck tractor, tandem axle trailer	Maximum 42 000 kg	Maximum 42 000 kg
(e) Three axle truck tractor, tridem axle trailer	Maximum 45 000 kg	Maximum 45 000 kg
(i) Tridem Spread 2.4 m to 3.0 m	Maximum 47 000 kg	Maximum 47 000 kg
(ii) Tridem Spread >3.0 m to 3.6 m	Maximum 48 000 kg	
(iii) Tridem Spread >3.0 m to 3.6 m on Highways listed in Appendix E (Note 1)	Maximum 48 000 kg	Maximum 48 000 kg
(iv) Tridem Spread >3.6 m to 3.7 m		

Note 1: The maximum allowable weight on a tridem axle group on a semi-trailer with a spread greater than 3.0 m up to 3.6 m is 24 000 kg on provincial highways or portions of provincial highways listed in Appendix E.

Appendix B

Requirements for Over-dimension D Signs

[Clause 2(1)(s) and Subsection 11(1)]

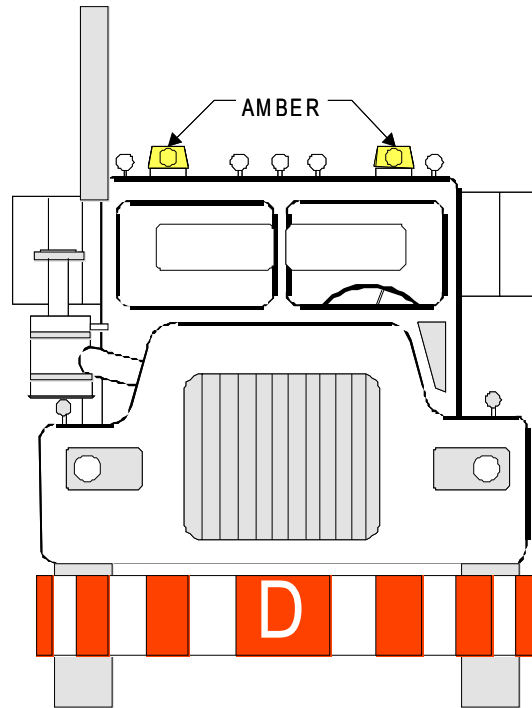

Appendix C

Escort Vehicles

[Clause 2(1)(y) and subsection 13(1)]

Two-way radios required

1 If a permit for exceeding the dimensions set out in the regulations is issued pursuant to section 36 of the Act and the permit requires the permit holder to use an escort vehicle, two-way radio communication must be maintained between the operator of the escort vehicle, the operator of the unit towing the over-dimensional load and all other vehicles required by the permit at all times

Equipment to be carried on escort vehicle

2 Every escort vehicle must carry the following equipment:

- (a) one stop/slow paddle or red flag per crew member for the purpose of traffic control;
- (b) one brightly coloured vest, shirt or jacket that must not be covered by any other clothing or article and that must be worn when flagging traffic;
- (c) a fire extinguisher approved by the Underwriters' Laboratory, having a rating of 5BC and kept fully charged;
- (d) flares, lanterns or reflectors that:
 - (i) are to be used to mark the hazard in the event of a breakdown or accident; and
 - (ii) are visible for 150 metres under normal weather conditions and while the hazard exists.

Signs to be mounted on escort vehicle

3(1) Every escort vehicle must have mounted on its roof a "D" sign or a "Wide Load", or "Long Load" or "Oversize Load" sign.

(2) The sign mentioned in subsection (1) must comply with the following requirements:

- (a) the sign must have two positions:
 - (i) upright, displaying the symbol or sign when escorting a load; and
 - (ii) folded flat, when not escorting a load;
- (b) the sign box must:
 - (i) be constructed of durable material suitable for use of the sign in all weather and highway conditions;
 - (ii) be 180 centimetres by 35 centimetres in dimension;
 - (iii) be self-illuminated to provide uniform lighting of the sign message to ensure the sign is visible from a distance of 300 metres under clear conditions at night;
 - (iv) shelter all wire connectors, switches and flashers; and
 - (v) protect and seal its interior from the elements;

- (c) in the case of a “D” sign, the sign must:
 - (i) have a white background;
 - (ii) have vertical red bars; and
 - (iii) have the size and positioning of the bars and letter “D” as specified in the attached diagram of the “D” sign;
 - (d) in the case of “Wide Load”, “Long Load” or “Oversize Load” signs, the signs must have a yellow background with black lettering as specified in the attached diagram of the “Wide Load”, “Long Load” or “Oversize Load” sign; and
 - (e) the sign must:
 - (i) be kept in good repair; and
 - (ii) be kept clean and legible at all times.
- (3) Every escort vehicle must have two 175 millimetre flashing amber outboard lights that meet the requirements of SAE Standard J595.
- (4) Every escort vehicle must be equipped with two amber inboard rotating or flashing amber lights that are at least 200 millimetres in diameter and in the case of rotating lights, be equipped with two sealed beams in each unit.

17 Aug 2018 SR 50/2018 s10.

Operation of escort vehicle

- 4(1) If an escort vehicle is preceding the vehicle transporting an over-dimensional load, the escort vehicle must precede the vehicle transporting the over-dimensional load by at least 300 metres but not more than 1000 metres.
- (2) If an escort vehicle is following the vehicle transporting an over-dimensional load, the escort vehicle must follow at a distance of not more than 300 metres.
- (3) A vehicle, while engaged as an escort vehicle, must not:
- (a) tow any trailer or other vehicle; or
 - (b) carry any load that, in any manner:
 - (i) obscures any lights or signs that the escort vehicle is required to be equipped with; or
 - (ii) obscures or interferes with the view of the operator of the escort vehicle.

30 Jne 2011 SR 46/2011 s11.

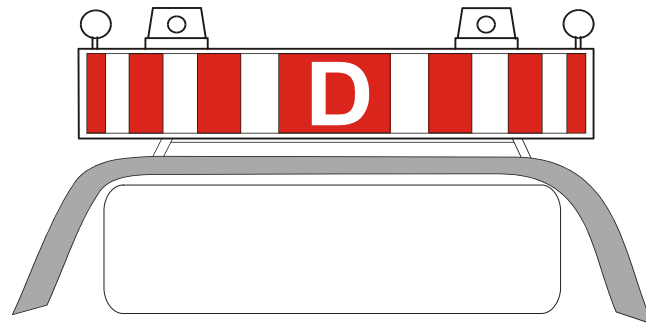
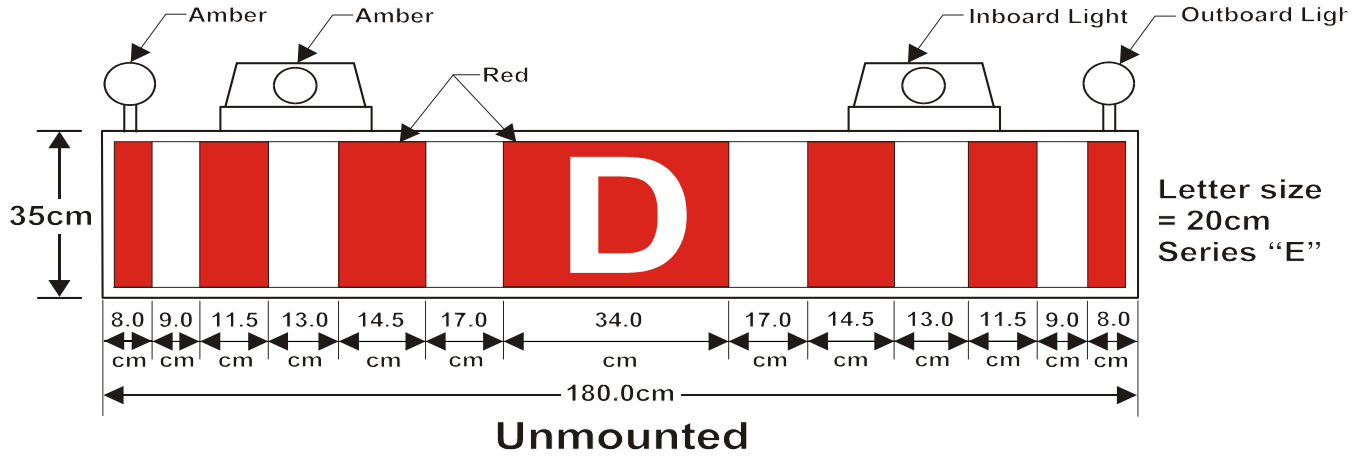

CARRIAGE UNIT

Car Top Carrier Type or Unit
of Adequate Design

Mounted



Appendix D
Primary Highways
 [Section 15]

The following highways or portions of public highways are primary highways for the purposes of Part IV:

- (a) Provincial Highway No. 1;
- (b) Provincial Highway No. 1A;
- (c) Provincial Highway No. 2, from Assiniboia to La Ronge;
- (d) Provincial Highway No. 3, from Hudson Bay to its junction with Provincial Highway No. 40;
- (e) Provincial Highway No. 4, from Swift Current to Meadow Lake;
- (f) Provincial Highway No. 5, from its junction with Provincial Highway No. 57 to Saskatoon;
- (g) Provincial Highway No. 6, from the International Boundary to Melfort;
- (h) Provincial Highway No. 7;
- (i) Provincial Highway No. 8, from Moosomin to Rocanville;
- (j) Provincial Highway No. 9, from the International Boundary to Hudson Bay;
- (k) Provincial Highway No. 10;
- (l) Provincial Highway No. 11;
- (m) Provincial Highway No. 11A;

H-3.01 REG 8 VEHICLE WEIGHT AND DIMENSION, 2010

- (n) Provincial Highway No. 12, from Saskatoon to its junction with Provincial Highway No. 40;
- (o) Provincial Highway No. 13, from the Manitoba Boundary to Weyburn;
- (p) Provincial Highway No. 14;
- (q) Provincial Highway No. 15, from its junction with Provincial Highway No. 11 to its junction with Provincial Highway No. 4;
- (r) Provincial Highway No. 16;
- (s) Provincial Highway No. 17, from its junction with Provincial Highway No. 14 to its junction with Provincial Highway No. 3;
- (t) Provincial Highway No. 18, from the Manitoba Boundary to its junction with Provincial Highway No. 39;
- (u) Provincial Highway No. 22, from 21.6 kilometres east of Esterhazy to its junction with Provincial Highway No. 9;
- (v) Provincial Highway No. 27;
- (w) Provincial Highway No. 29;
- (x) Provincial Highway No. 33, from Kronau to Regina;
- (y) Provincial Highway No. 35, from Elfros to Nipawin;
- (z) Provincial Highway No. 37, from Shaunavon to Gull Lake;
- (aa) Provincial Highway No. 39;
- (bb) Provincial Highway No. 40, from its junction with Provincial Highway No. 3 to North Battleford;
- (cc) Provincial Highway No. 41;
- (dd) Provincial Highway No. 41A;
- (ee) Provincial Highway No. 46;
- (ff) Provincial Highway No. 47, from the International Boundary to Estevan;
- (gg) Provincial Highway No. 48 from Gregory Avenue in White City to the north service road;
- (hh) Provincial Highway No. 55, from its junction with Provincial Highway No. 23 to Prince Albert;
- (ii) Provincial Highway No. 55, from its junction with Provincial Highway No. 3 to Meadow Lake;
- (jj) Provincial Highway No. 57;
- (kk) Provincial Highway No. 80, from its junction with Provincial Highway No. 22 to 11 kilometres north-east of its junction with Provincial Highway No. 22;
- (ll) Provincial Highway No. 305 from its junction with Provincial Highway No. 12 to its junction with Provincial Highway No. 11;
- (mm) Provincial Highway No. 316;
- (nn) Provincial Highway No. 364, from Balgonie to Edenwold;
- (oo) Provincial Highway No. 397;

- (pp) any provincial road between a highway mentioned in clauses (a) to (oo) and:
 - (i) the Belle Plaine potash mine, south-west corner of the south-east quarter of Section 14, Township 17, Range 24, West of the Second Meridian;
 - (ii) the Cory potash mine located in Section 18, in Township 36, in Range 6, West of the Third Meridian;
 - (iii) the Vanscoy potash mine located in Section 16, in Township 35, in Range 8, West of the Third Meridian;
 - (iv) the Esterhazy potash mine located in Section 24, in Township 20, in Range 33, West of the First Meridian;
 - (v) the Lanigan potash mine located in Section 28, in Township 33, in Range 23, West of the Second Meridian;
 - (vi) the Patience Lake potash mine located in Section 16, in Township 36, in Range 3, West of the Third Meridian; or
 - (vii) the Rocanville potash mine located in Section 21, in Township 17, in Range 30, West of the First Meridian;
- (qq) the public highway (service road) north of Provincial Highway No.1 from Provincial Highway No. 46 to Tower Road;
- (rr) the public highway (service road) south of Provincial Highway No. 1 from Great Plains Industrial Drive, Emerald Park to Provincial Highway No. 33;
- (ss) Pilot Butte Access road from its junction with the service road south of Highway No. 1 to its junction with the service road north of Highway No. 1;
- (tt) Grid Road 734 (Zehner Road) from its junction with Provincial Highway No. 6 to its junction with Provincial Highway No. 11;
- (uu) a maximum distance of 15 kilometres on any secondary provincial highway or any provincial road or a maximum cumulative distance of 15 kilometres on any number of secondary highways from the point of intersection of the first secondary provincial highway with a highway mentioned in clauses (a) to (oo), except for the following:
 - (i) Provincial Highway No. 364 east of Edenwold to Provincial Highway No. 10;
 - (ii) Provincial Highway No. 312 commencing at the western abutment of the Gabriel Dumont Bridge, eastward over the South Saskatchewan River;
- (vv) a maximum of 15 kilometres on any provincial highway from its intersection with the boundary of any urban municipality that:
 - (i) has a population of 1,000 or more; and
 - (ii) has its boundary intersected by a highway mentioned in clauses (a) to (oo).

Appendix E**Provincial Highways or Portions of Provincial Highways on
Which B-trains Can Operate at 63,500 kg**
[Sections 16 and 18]

- (a) Provincial Highway No. 1;
- (a.1) Provincial Highway No. 1A;
- (b) Provincial Highway No. 2, from Assiniboia to La Ronge;
- (c) **Repealed.** 30 Oct 2015 SR 92/2015 s10.
- (d) **Repealed.** 30 Oct 2015 SR 92/2015 s10.
- (e) Provincial Highway No. 3, from Hudson Bay to its junction with Provincial Highway No.40;
- (f) Provincial Highway No. 4, from its junction with Provincial Highway No. 1 to Meadow Lake;
- (g) Provincial Highway No. 5, from Saskatoon to Canora;
- (h) Provincial Highway No. 6, from the International Boundary to Melfort;
- (i) Provincial Highway No. 7;
- (j) Provincial Highway No. 8 from its junction with Provincial Highway No. 1 to its intersection with Grid Road No. 719;
- (k) Provincial Highway No. 9, from its junction with Provincial Highway No. 13 to Canora;
- (l) Provincial Highway No. 9, from the International Boundary to its junction with Provincial Highway No. 18;
- (m) Provincial Highway No. 10;
- (n) Provincial Highway No. 11;
- (n.1) Provincial Highway No. 11A;
- (o) Provincial Highway No. 12, from Saskatoon to its junction with Provincial Highway No. 312;
- (p) Provincial Highway No 13 from the Manitoba Boundary to its junction with Provincial Highway No. 39;
- (q) Provincial Highway No. 14, from Saskatoon to the Alberta Boundary;
- (r) Provincial Highway No. 15, from its junction with Provincial Highway No. 4 to its junction with Provincial Highway No. 11;
- (s) Provincial Highway No. 16;
- (t) Provincial Highway No. 17;
- (u) Provincial Highway No 18 from the Manitoba Boundary to its junction with Provincial Highway No. 39;
- (v) Provincial Highway No. 22, from the Esterhazy Potash Mine access to Stockholm;
- (w) Provincial Highway No. 29;

- (w.1) Provincial Highway No. 33 from Richardson to its junction with Provincial Highway No. 1;
- (x) Provincial Highway No. 35, from its junction with Provincial Highway No. 16 to its junction with Provincial Highway 55 at Nipawin;
- (y) Provincial Highway No. 39, from North Portal to its junction with Provincial Highway No. 1;
- (z) Provincial Highway No. 40, from its junction with Provincial Highway No. 3 to its junction with Provincial Highway No. 29;
- (aa) Provincial Highway No. 41, from its junction with Provincial Highway No. 5 to its junction with Provincial Highway No. 6;
- (bb) Provincial Highway No. 41A, from its junction with Provincial Highway No. 41 to its junction with Provincial Highway No. 3;
- (bb.1) Provincial Highway No. 46;
- (cc) Provincial Highway No. 55, from its junction with Provincial Highway No. 3 to its junction with Highway No. 4;
- (dd) **Repealed.** 17 Aug 2018 SR 50/2018 s12.
- (ee) Provincial Highway No. 316;
- (ee.1) Provincial Highway No. 397;
- (ff) the Belle Plaine potash mine access road from Provincial Highway No. 1 to the south-west corner of the south-east quarter of Section 14, Township 17, Range 24, West of the Second Meridian;
- (gg) the Rocanville potash mine access road from Provincial Highway No. 8 to Section 21, Township 17, Range 30 West of the First Meridian;
- (hh) the Cory potash mine access road from Provincial Highway No. 7 to Section 18, in Township 36, in Range 6, West of the Third Meridian;
- (ii) the Vanscoy potash mine access road from Provincial Highway No. 7 to Section 16, in Township 35, in Range 8, West of the Third Meridian;
- (jj) the Esterhazy potash mine access road from Provincial Highway No. 22 to Section 24, in Township 20, in Range 33, West of the First Meridian;
- (kk) the Lanigan potash mine access road from Provincial Highway No. 16 to Section 28, in Township 33, in Range 23, West of the Second Meridian;
- (ll) the Patience Lake potash mine access road from Provincial Highway No. 316 to Section 16, in Township 36, in Range 3, West of the Third Meridian;
or
- (mm) Provincial Road 903 from its junction with Provincial Highway No. 55 to 1.52 km North;
- (nn) the public highway (service road) north of Provincial Highway No. 1 from Provincial Highway No. 46 to Tower Road;

H-3.01 REG 8 VEHICLE WEIGHT AND DIMENSION, 2010

- (oo) the public highway (service road) south of Provincial Highway No. 1 from Great Plains Industrial Drive, Emerald Park to Provincial Highway No. 33;
- (pp) Pilot Butte Access road from its junction with the service road south of Highway No. 1 to its junction with the service road north of Highway No. 1;
- (qq) Rotary Avenue from Provincial Highway No. 11 to the Global Transportation Hub;
- (rr) all public highways within the Global Transportation Hub boundary; or
- (ss) Grid Road 734 (Zehner Road) from its junction with Provincial Highway No. 6 to its junction with Provincial Highway No. 11.

11 Apr 2014 SR 13/2014 s13; 30 Oct 2015 SR
92/2015 s10; 17 Aug 2018 SR 50/2018 s12;
25 Sep 2020 SR 106/2020 s6; 28 Oct 2022 SR
81/2022 s10.